

AMBIRAD

ENERGY EFFICIENT HEATING SYSTEMS

OWNER'S MANUAL

VACUUM SERIES INDIVIDUAL INFRARED HEATERS

SC- SERIES

ER- SERIES

GX- SERIES

IMPORTANT: Thoroughly read this instruction manual before performing Installation, Servicing, and Maintenance procedures. Follow all warnings or cautions included in this literature and attached to the unit. Consult local building codes and National Electric Code (NEC) for special requirements.

ER Series
1b101 — cvr

NOTE: Standard reference to ER- Series

—INDEX—

A. INSTALLATION INSTRUCTIONS	1
1. TECHNICAL DATA	1
(a) General Information	
(b) ER-Series Heating Models (SC & GX)	
(c) Typical Arrangement of Heater	
2. PACKAGING AND SHIPPING INFORMATION	3
3. MOUNTING CLEARANCES	4
4. PRE-ASSEMBLY	5
5. INSTALLATION	5
6. GAS CONNECTION	6
7. ELECTRICAL CONNECTION	8
(a) Burner/Control Internal Wiring	
(b) Typical External Wiring	
8. VENT REQUIREMENTS & DETAILS	9
(a) Unvented units	
(b) Vertical Vent	
(c) Horizontal Vent	
9. FRESH AIR DUCTED INTAKE	10
(a) Vertical Thru Roof	
(b) Horizontal Thru Wall	
10. INSTALLATION CHECK OUT AND START UP	11
B. SERVICE AND MAINTENANCE INSTRUCTIONS	13
1. Servicing Instructions	
2. Routine Service	
3. Replacement of Components	
4. Users Instructions	
C. APPENDIX 'A'	18

NOTE: All reference to standard specifications, codes, regulations, etc. are intended to reflect latest editions included in the ANSI Testing, Construction, Performance and Installation Standards. (ANSI/NFPA standard 1985)

SAFETY CONSIDERATIONS

Improper installation, adjustment, alteration, service, maintenance, or use can cause explosion, fire, electrical shock, or other conditions which may cause death, personal injury, or property damage. Consult a qualified installer, service agency, or your distributor or branch for information and assistance. The qualified installer or agency must use factory-authorized kits or accessories when modifying this product. Refer to specific instructions packaged with the kits or accessories when installing.

Follow all safety codes. Wear safety glasses, protective clothing, and work gloves.

Recognize safety information indicated by the safety-alert symbol (▲). When you see this symbol on the unit and in instructions or manuals, be alert to the potential for personal injury.

Understand the signal word **DANGER**, **WARNING**, or **CAUTION**. These words are used with the safety-alert symbol. The word **DANGER** identifies the most serious hazards which **will** result in severe personal injury or death. **WARNING** signifies hazards which **could** result in personal injury or death. **CAUTION** is used to identify unsafe practices which **would** result in minor personal injury or product and property damage.

A. INSTALLATION INSTRUCTIONS

A.1 TECHNICAL DATA

(a) General Information

Model and Heat Input See chart (p. 2) for units available in ER, GX, and SC series.

(b) ER, GX, and SC Units

Gas Supply Connection..... 1/2-inch NPT male
Electrical Supply 120VAC, single phase, 60 Hz
Current Rating 1.2A max. (burner — 0.3A; fan — 0.9A)
Ignition Electronic program start-up with spark ignition

OPTIONS:

- Modify combustion chamber air intake for fresh air duct.
- Ambi-Rad black bulb thermostat.
- Control panel with multi-zone capabilities. (Not A. G. A. certified)
- Individual heater vent to exterior.

NOTES:

- Heater is intended for heating non-residential indoor and outdoor spaces. **DO NOT** install heater where flammable gases or vapors are present.
- Indoor heaters may be suspended either horizontally or at an angle, or may be wall-mounted. Outdoor heaters must be suspended horizontally. See Section A.3 for clearance dimensions.
- Installation shall conform with local building code requirements and with National Fuel Code ANSI-Z223.1.A (latest edition) and Section 7.8A-3; Z223.1 (latest edition).
- The unit shall be electrically grounded in accordance with National Electric Code ANSI/NFPA 70-1987.
- The heater may be installed in aircraft hangars when conforming with ANSI/NFPA 409-1985 for Aircraft Hangars and in automotive garages when conforming with ANSI/NFPA 88A (latest edition) for Parking Structures and ANSI/NFPA 88B (latest edition) for Repair Garages.

▲ WARNING: Minimum clearance from heater must be maintained from vehicles parked below heater. In all situations, clearances to combustibles must be maintained. Signs should be posted in storage areas to specify maximum stacking height to maintain required clearance to combustibles. Refer to mounting clearance tables on pages 4 and 5.

HEATER SELECTION CHART

MODEL DESIGNATION		DESIGN CHARACTERISTICS												INFORMATION					
SERIES	INPUT Btu/h	U-TUBE						STRAIGHT TUBE						TUBE TYPE		REFLECTOR	NOTE	COMMENTS	
		U20	U30	U35	S20	S25	S30	S35	S40	S45	S50	S55	S60	S65	S70				DIA. (in.)
SCORPIO	SC12	40,000	○	○															1. SE1—STRAIGHT TUBE UNITS W/ ONE 90° ELBOW.
	SC15	50,000	○	○															
	SC18	60,000	○	○															
	SC22	75,000	○	○															2. SE2—STRAIGHT TUBE UNITS W/ TWO 90° ELBOWS.
ER	SC29	100,000		○															
	SC38	130,000		○															
	SC44	150,000		○															
	ER12	40,000	○	○															3. OPTIONAL COMBUSTION CHAMBER OF STAINLESS STEEL.
ER	ER15	50,000	○	○															
	ER18	60,000	○	○															
	ER22	75,000	○	○															
	ER29	100,000		○															
ER	ER38	130,000		○															
	ER44	150,000		○															
	GX12	40,000	○	○															
	GX15	50,000	○	○															
ER	GX18	60,000	○	○															
	GX22	75,000	○	○															
	GX29	100,000		○															
	GX38	130,000		○															
ER	GX44	150,000		○															

MODEL DESIGNATION (TYPICAL)
GX38 - S50 - SE2 - LP - A

NOTES: 1. ALL UNITS STANDARD W/ NATURAL GAS SUPPLY, 120V CONTROL SYSTEM, UNVENTED.
2. OPTIONS:
A. LIQUID PETROLEUM SUPPLY (LP SUFFIX)
B. DUCTED COMBUSTION AIR INTAKE ADAPTOR (A SUFFIX)
C. VENTED DESIGN (V SUFFIX)
D. UNITS EQUIPPED FOR OUTDOOR USE (O PREFIX).

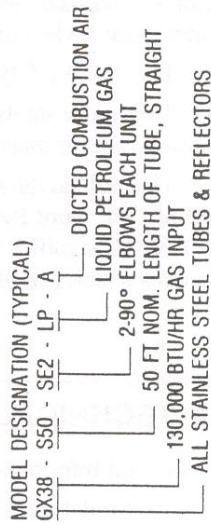

A.1 TECHNICAL DATA (CONT.)
 (c) Typical Arrangement of Heater

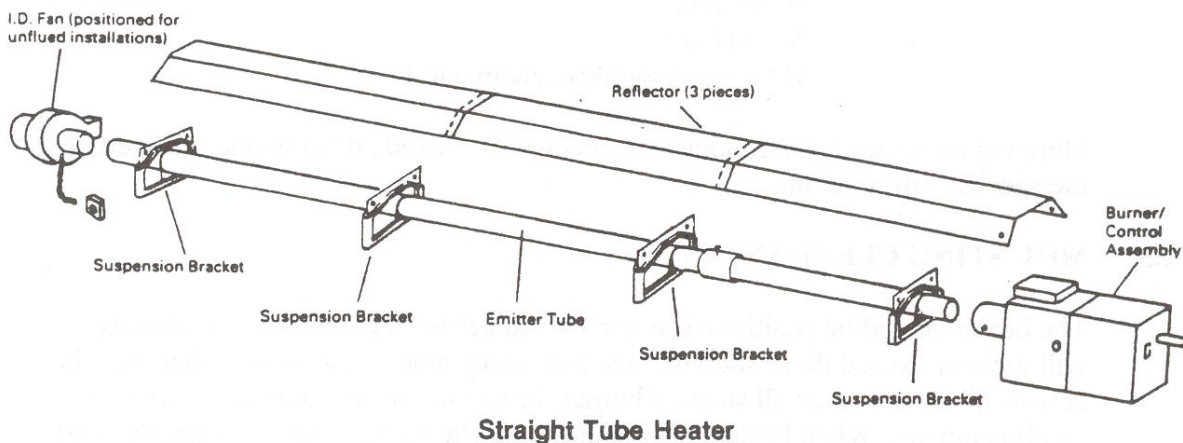

Straight Tube Heater

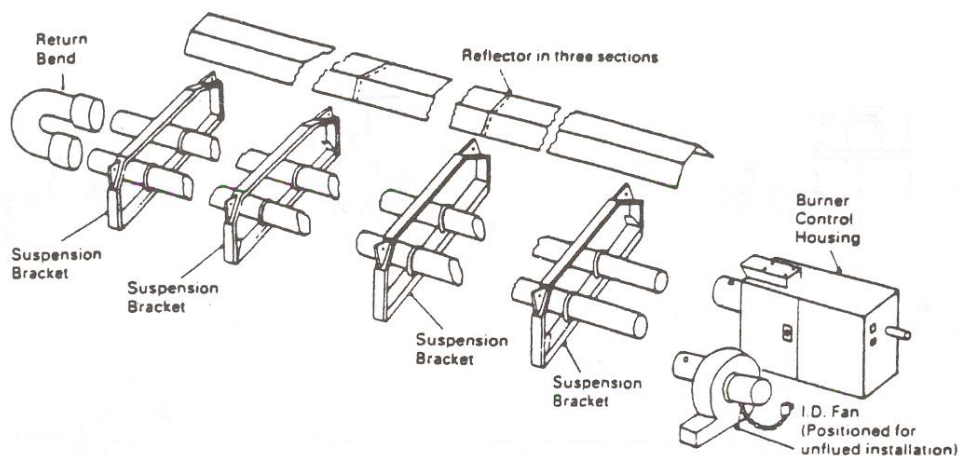

U-Tube Heater

NOTE: Refer to line drawings as shown in rear section of Manual.

A.2 PACKAGING AND SHIPPING INFORMATION

See Appendix 'A' for assembly drawings. Material lists with part numbers and descriptions for each part will accompany each shipment.

- Heaters include:
- Burner/Control
 - Radiant Tubes
 - Reflectors
 - Brackets
 - Vacuum Fan
 - U-Bend (U-Tube Units only)

A.2 PACKAGING AND SHIPPING INFORMATION (CONT.)

Options:

- Fresh Air Intake (Mounted to Burner/Control)
- Fan Vent Adapters – Vertical and Horizontal
- Thermostat
- Flexible Gas Connector
- Ball Valve
- Vent Hoods
- Hanging Assembly (chain, etc.)

Shipping packages for individual projects will be boxed and crated as outlined on the specific bill of lading.

A.3 MOUNTING CLEARANCES

The heater should be positioned so that clearances from combustible materials will meet or exceed those shown in the following table. Also, ensure that there is at least 6" clearance on all sides of burner for service access and for free flow of combustion air. When heater is angle mounted, the burner/control assembly must remain horizontal.

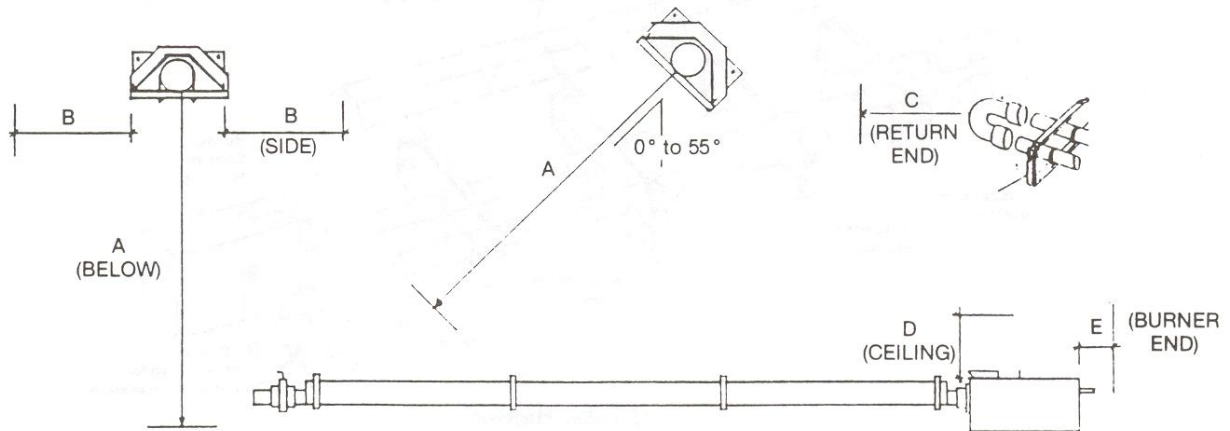

FIGURE 2: MINIMUM CLEARANCES TO COMBUSTIBLE MATERIALS

Minimum Clearances To Combustibles

Model	Input-BTU/HR	A	B	C	D	E
SC/ER/GX 12	40,000	43	20	48	4	6
SC/ER/GX 15	50,000	66	20	48	10	6
SC/ER/GX 18	60,000	66	20	48	10	6
SC/ER/GX 22	75,000	66	20	48	10	6
SC/ER/GX 29	100,000	72	30	48	12	6
SC/ER/GX 38	130,000	72	30	48	12	6
SC/ER/GX 44	150,000	93	36	48	12	6

A.3 MOUNTING CLEARANCES (CONT.)

Mounting Position	Mounting Height Above Floor		
	40,000-75,000 B.T.U.	100,000-130,000 B.T.U.	150,000 B.T.U.
Horizontal			
Recommended	14 FT	16 FT	18 FT
Minimum	12 FT	14 FT	16 FT
Inclined			
Recommended	11 FT	13 FT	15 FT
Minimum	10 FT	12 FT	14 FT

Ensure that there is adequate provision in the building for combustion and ventilating air supply. Installation must meet minimum requirements of applicable codes.

	<p>WARNING: FIRE OR EXPLOSION HAZARD — can cause death, severe injury, or property damage. Failure to maintain specified minimum clearances to combustibles could result in a serious fire hazard. DO NOT locate flammable or combustible materials within minimum distances specified in the preceding tables.</p>
<p>ER Series 1b103 — p5</p>	

A.4 PRE-ASSEMBLY

Each heating unit is assembled as follows:

NOTE: Each heating unit has two types of emitter tubes. Depending on the model, the first tube connected to the burner control will be either aluminized steel (marked with yellow paint) or stainless steel (marked with red paint). The mild steel tube (marked with blue paint) should never be connected to the burner control. The tubes are connected with stainless steel couplings, refer to the “TUBE COUPLING DETAIL” for coupling installation.

NOTE: Refer to the “COMBUSTION TUBE SEAM LOCATION DETAIL” to insure proper installation of the radiant combustion tube.

Slip the suspension brackets onto the tube assembly and attach by means of “U” bolts and nuts. Note that there are three types of brackets; type A, type B, and type C. Type A has additional reflector locating lugs. Brackets are placed on the assembled radiant tube in positions shown on the assembly drawing. Tighten brackets to the tubes at spacings indicated with all brackets oriented in the same level position.

The straight heaters can use A & B brackets in fixed positions or A, B, & C brackets with the B brackets free to move to suit the roof structure.

A.5 INSTALLATION

Heater Units: At this point raise the tube assembly into position and suspend from previously fixed chains (9 gauge min. Galvanized welded link construction), or attach to wall mounting brackets. Wall mounting brackets must support heater at an angle of inclination of $45^\circ \pm 10^\circ$. Longer tube assembly may be raised in more than one sub-assembly with final tube connection made in the air.

A.5 INSTALLATION (CONT.)

It is recommended that the heater be suspended to slope slightly downward from the burner approximately 1-inch in 20-feet, but not more than 2-inches total.

Remove the protective plastic film from the reflector surface. Note that each section of reflector has two holes punched at one end. This end is firmly fixed by bolting to the lugs provided on suspension bracket type A. The other end of each reflector section is free floating in suspension bracket type B thereby allowing for thermal expansion.

Where 'C' brackets are used on straight heaters the reflectors are bolted together or allowed to float as shown.

Position reflector sections so that ends with holes lap at Type A brackets and secure with nuts, bolts and large washers provided in the burner box crate. Reflectors should be allowed free movement through brackets type B and in some C brackets. Note: reflectors may be installed before tube is raised to position at installers option.

Slide burner/control assembly onto the burner end of the radiant tube ensuring it is fully engaged and upright, (i.e., with air inlet cover plate facing upwards) and secure with locking screws provided.

Slide the fan assembly on the opposite end of radiant tube, ensuring that it is fully engaged with fan outlet facing horizontally for outdoor installations and for indoor installations either unvented or with horizontal thru wall venting. Fan outlet should face upward for vertical venting thru the roof.

A.6 GAS CONNECTION

The gas connection on the heater is 1/2" NPT external thread.

SERVICE REQUIREMENTS	Nat. Gas	L.P. Gas
max. inlet gas supply pressure (in. w.c.)	14.0	14.0
min. inlet gas supply pressure (in. w.c.)	6.5	11.0

Injector sizes and manifold pressure for the burner are shown in the attached table for all heater units.

The gas supply piping and connections must be installed so that the minimum pressure stated is achieved.

A gas shut off valve and union should be fitted in the gas supply line close to the heater, and a 1/8" NPT plugged tapping, accessible for test gauge connection, provided immediately upstream of the appliance gas inlet.

<p>⚠ WARNING: FIRE OR EXPLOSION HAZARD — Expansion of the radiant pipe occurs with each firing cycle causing the burner to move with respect to the gas line. This can result in a gas leak producing an unsafe condition. It is therefore essential to provide some flexibility in the final gas line connection — preferably by use of an approved armoured flexible connector or stainless steel expansion loop (see “SUGGESTED SERVICE CONNECTIONS” drawing in Appendix “A”).</p>
--

ER Series
1b104—p6

TABLE ONE

MODEL DESIGNATION				ORIFICES		NATURAL GAS		*LIQUIFIED PETROLEUM	
	INPUT KW/BTU	MODEL TUBE CONFIG.	TUBE DIA. (IN.)	BURNER INTAKE (IN./MM)	FAN INTAKE (IN./MM)	INJECTOR DIAMETER (IN./MM)	MANIFOLD PRESSURE (IN. W.C.)	INJECTOR DIAMETER (IN./MM)	MANIFOLD PRESSURE (IN. W.C.)
SC/ER/GX	12/40,000	S-20	3"	1.125"/29MM	1.312"/34MM	0.130"/3.3	1.9"	0.080"/2.0	6.7"
		S-25	3"	1.125"/29MM	1.438"/37MM	0.130"/3.3	1.9"	0.080"/2.0	6.7"
		S-30	3"	1.125"/29MM	1.438"/37MM	0.130"/3.3	1.9"	0.080"/2.0	6.7"
		U-20	3"	1.125"/29MM	1.187"/30MM	0.130"/3.3	1.9"	0.080"/2.0	6.7"
		U-30	3"	1.125"/29MM	1.187"/30MM	0.130"/3.3	1.9"	0.080"/2.0	6.7"
SC/ER/GX	15/50,000	S-20	3"	1.312"/33MM	1.438"/37MM	0.130"/3.3	3.0"	0.080"/2.0	10.5"
		S-25	3"	1.125"/29MM	1.438"/37MM	0.130"/3.3	3.0"	0.080"/2.0	10.5"
		S-30	3"	1.125"/29MM	1.438"/37MM	0.130"/3.3	3.0"	0.080"/2.0	10.5"
		U-20	3"	1.312"/33MM	1.438"/37MM	0.130"/3.3	3.0"	0.080"/2.0	10.5"
		U-30	3"	1.312"/33MM	1.312"/34MM	0.130"/3.3	3.0"	0.080"/2.0	10.5"
SC/ER/GX	18/60,000	S-20	3"	1.750"/44MM	2.00"/50MM	0.161"/4.1	2.4"	0.098"/2.5	6.7"
		S-25	3"	1.312"/33MM	1.438"/37MM	0.161"/4.1	2.4"	0.098"/2.5	6.7"
		S-30	3"	1.312"/33MM	1.438"/37MM	0.161"/4.1	2.4"	0.098"/2.5	6.7"
		S-40	3"	1.312"/33MM	1.438"/37MM	0.161"/4.1	2.4"	0.098"/2.5	6.7"
		U-20	3"	1.312"/33MM	1.750/44MM	0.161"/4.1	2.4"	0.098"/2.5	6.7"
		U-30	3"	1.312"/33MM	1.438"/37MM	0.161"/4.1	2.4"	0.098"/2.5	6.7"
SC/ER/GX	22/75,000	S-20	3"	1.750"/44MM	2.625"/67MM	0.161"/4.1	3.8"	0.098"/2.5	10.5"
		S-25	3"	1.750"/44MM	2.00"/50MM	0.161"/4.1	3.8"	0.098"/2.5	10.5"
		S-30	3"	1.750"/44MM	2.00"/50MM	0.161"/4.1	3.8"	0.098"/2.5	10.5"
		S-40	3"	1.750"/44MM	1.75"/44MM	0.161"/4.1	3.8"	0.098"/2.5	10.5"
		U-20	3"	1.750"/44MM	2.625"/67MM	0.161"/4.1	3.8"	0.098"/2.5	10.5"
		U-30	3"	1.750"/44MM	2.00"/50MM	0.161"/4.1	3.8"	0.098"/2.5	10.5"
SC/ER/GX	29/100,000	S-40	4"	2.312"/58MM	2.00"/50MM	0.182"/4.6	4.9"	0.120"/3.0	10.0"
		S-50	4"	2.312"/58MM	2.00"/50MM	0.182"/4.6	4.9"	0.120"/3.0	10.0"
		S-60	4"	2.312"/58MM	2.00"/50MM	0.182"/4.6	4.9"	0.120"/3.0	10.0"
		U-35	4"	2.312"/58MM	2.00"/50MM	0.182"/4.6	4.9"	0.120"/3.0	10.0"
SC/ER/GX	38/130,000	S-40	4"	2.312"/58MM	2.625"/67MM	0.206"/5.2	4.9"	0.136"/3.45	10.0"
		S-50	4"	2.312"/58MM	2.625"/67MM	0.206"/5.2	4.9"	0.136"/3.45	10.0"
		S-60	4"	2.312"/58MM	2.625"/67MM	0.206"/5.2	4.9"	0.136"/3.45	10.0"
		U-35	4"	2.312"/58MM	2.625"/67MM	0.206"/5.2	4.9"	0.136"/3.45	10.0"
SC/ER/GX	44/150,000	S-40	4"	2.312"/58MM	4.00"/100MM	0.228"/5.8	4.6"	0.149"/3.8	10.0"
		S-50	4"	2.312"/58MM	4.00"/100MM	0.228"/5.8	4.6"	0.149"/3.8	10.0"
		S-60	4"	2.312"/58MM	4.00"/100MM	0.228"/5.8	4.6"	0.149"/3.8	10.0"
		U-35	4"	2.312"/58MM	4.00"/100MM	0.228"/5.8	4.6"	0.149"/3.8	10.0"

*NOTE: For altitudes above 2000 ft. refer to separate table for L.P. injector diameter and pressure.

A.7 ELECTRICAL CONNECTIONS

(a) Burner/Control Internal Wiring

Important: All electrical work should be done by a qualified electrician in strict accordance with the National Electrical Code ANSI/NFPA 70.

Supply: 120V, 60 HZ, single phase

Current rating: 0.3 amp max.

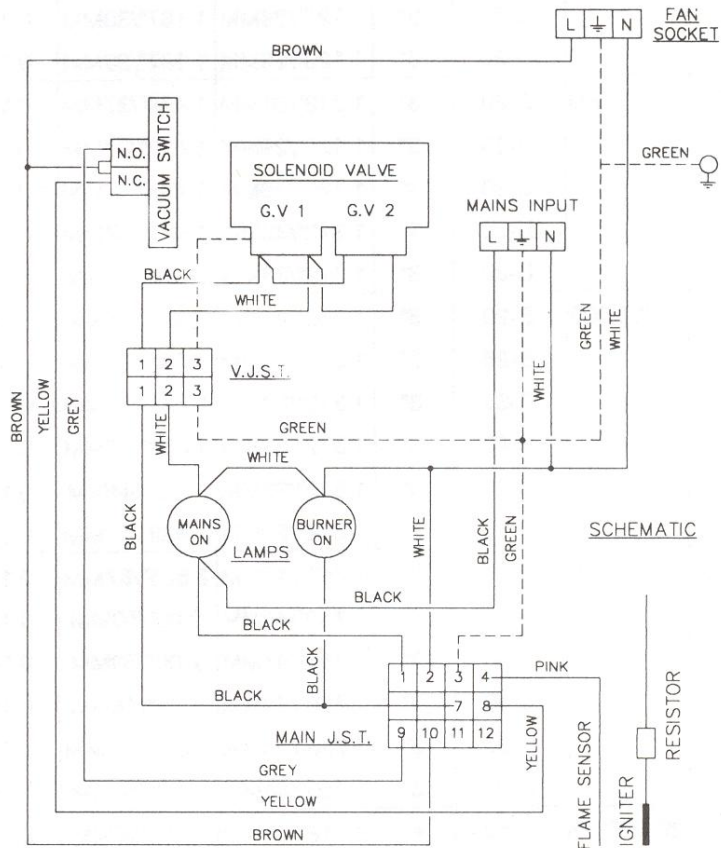

⚠ WARNING

Before making electrical connections, switch **OFF** the main electrical disconnect. There may be more than one disconnect switch. Lock out and tag switch with a suitable warning label. Electrical shock can cause personal injury or death.

ER Series, Ibl05 — p8

The electrical supply to the heater is by three wires; live, neutral, and ground connections. It is recommended that the supply cable be in metallic conduit to the $\frac{3}{4}$ " hole provided. An external 3 amp fuse should be included in the supply to each heater.

Power is supplied to the fan through the knock out on the side of the burner housing. Fan leads should be connected to the burner leads using the wire nuts that are provided. Connect white to white, green to green, and black to brown. Insure that conduit clamp is firmly tightened.

It is recommended that the electrical circuit controlling the heater or group of heaters include thermostats, a time switch and if required manual control switches. All such controls and switch gear must be rated to handle the total inductive load of the circuit they control. For large installations the use of relays or contactors should be considered.

A.7 ELECTRICAL CONNECTIONS (CONT.)

Control panels are available from the Manufacturer incorporating multiple Black Bulb Thermostats controlling up to 10 heaters per thermostat for zone control of the heater area. Typical External Wiring is shown in the following diagram. (Control panels are not A.G.A. design certified.)

(b) Typical External Wiring

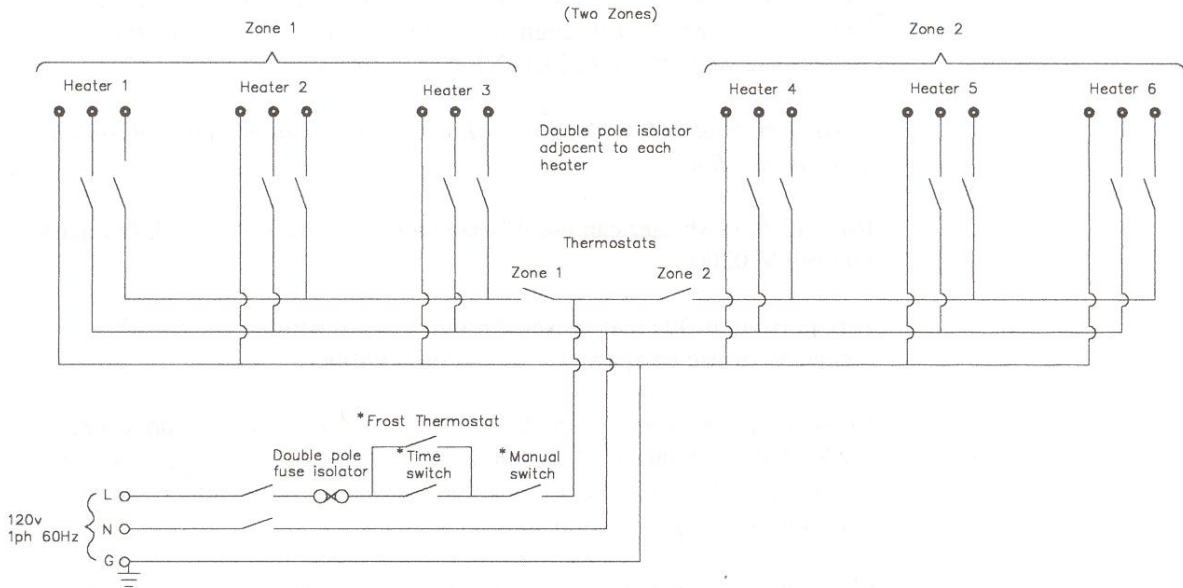

A.8 VENT REQUIREMENTS AND DETAILS

- (1) UNVENTED UNITS: Heaters may be installed with a flue providing the governing building codes are met and that consideration is properly given to possibilities of condensation on cold surfaces.

Installation shall meet the following requirements when unvented:

- (A) Internal volume of the heated room must be greater than 214 cu. ft. per 100 Btu/h of heaters installed.
 - (B) Natural or mechanical means shall be provided to supply and exhaust at least 4 CFM per 1,000 Btu per hour input of installed heaters.
 - (C) Combustion gases shall not impinge on combustible materials with a temperature in excess of 150°F.
 - (D) The blower discharge must be the lowest point of the flue.
- (2) VERTICAL VENTING: (See Appendix) The heater may be installed with a vertical flue.

(2 CONT.) VENT REQUIREMENTS AND DETAILS

All flue piping should be adequately supported from the building structure and terminated with an approved terminal. Maximum length of vent is 30 ft. with 2-90 degree long radius elbows for 6" diameter flue. Runs of 12 ft. or shorter can use a 4 inch diameter flue with Ambi-Rad, Inc. part number V-0200. All connections should be properly sealed. *Generally, terminal may be located horizontally a dimension equal to its vertical dimension.*

- (3) **HORIZONTAL VENTING:** (See Appendix) Individual units may be vented horizontally through side walls. Venting must be installed in accordance with ANSI Z223.1 (NFPA-54) and local codes.

Maximum length of vent is 25 ft. with 2-90 degree long radius elbows for 6" diameter flue.

Runs 12 ft. or shorter can use 4" diameter flue with Ambi-Rad, Inc. part number V-0200.

Any portion of flue that passes through a combustible wall must be insulated, or use an approved insulating thimble.

Recommended terminals are Ambi-Rad V-0700 for 4" flue and V-0800 for 6" flue. Standard vent terminals must extend at least 6" from the wall and at least 24" from any combustible overhang. Protect the building material from degradation by flue gases.

Flue joints should be sealed using RTV high temperature sealant and secured using at least 3 sheet metal screws. Should condensation occur flue should be shortened or insulated.

The terminal must exit the building at least 7 ft. above any area accessible to the public.

The terminal must be at least 3 ft. away from any air intake to the building.

The vent terminal must be protected from blockage by snow.

A.9 FRESH AIR DUCTED INTAKE

When the heater is installed in locations where airborne dust or other polluted atmosphere is present, a fresh air supply should be ducted to the burner.

A heater modified for fresh air intake should be specified when ordering. This model is modified with a 4" diameter duct connection at the burner.

A fresh air duct of 4" diameter should be installed from the fresh air terminal to the air intake connection on the burner housing. A flexible jointing piece should be installed at the burner connection with hose clamps to facilitate the disconnection when servicing the burner assembly.

A.9 FRESH AIR DUCTED INTAKE (CONT.)

The maximum recommended length of fresh air duct is 25 ft. and the maximum number of bends is two. The minimum length is 18 inches. The location of the fresh air duct inlet must be where it will receive dust free clean air. An inlet cap with bird screen must be fitted at the inlet of the duct. If the duct inlet is located above the roof the underside of the inlet terminal must be at least 2 ft. above roof level and at least 10 inches above any projection on the roof within 7 ft. of the inlet.

See Appendix 'A' for typical installation drawing and Ambi-Rad, Inc. part numbers. Intake pipe, fittings and sealant are *not* furnished by the Manufacturer.

A.10 INSTALLATION CHECK OUT AND START UP

Inspect installation and ensure that it has been carried out in accordance with these instructions. Ensure that electrical and gas supplies are isolated.

The gas supply should be purged and tested for soundness in accordance with local and National Safety codes.

Open isolating gas valve and test gas connections for soundness using soap solution.

Remove burner cover plate by unscrewing 6 screws. Take care not to damage the sealing gasket. Inspect the burner and electrode assemblies ensuring these are securely fixed and all electrical connections securely made. Replace the burner cover plate ensuring that the sealing gasket is correctly positioned and the six screws are fully tightened. The heater will not operate until this plate is refitted.

Remove the control housing cover plate by unscrewing the five securing screws.

Ensure all internal components are securely fixed and all connections securely made.

Switch on the electrical supply to the heater and observe the correct start up sequence. Ensure that the settings of any time switch and thermostat are such that the heating system will be required to operate.

The fan will start to run and "Power On" lamp will illuminate. Safe-start checks are carried out automatically.

After the fan has run up to full speed and a satisfactory vacuum condition has been established, the ignition sequence will commence. The spark ignition will be energized producing a spark at the ignition electrode. The gas solenoid valve will at the same time be energized.

A.10 INSTALLATION CHECK OUT AND START UP (CONT.)

If the ignition is successful the flame is detected by the flame sensing probe and the ignition spark is switched off after approximately 10 seconds. The “burner on” lamp indicates that the gas solenoid valve is energized.

If ignition is unsuccessful the gas valve will close and the spark ignition de-energized after approximately 10 seconds. For approximately 15 seconds the fan will purge the system then re-ignition will be attempted. After 3 attempts at ignition the control unit will “lock out”, the “power on” lamp will remain illuminated and the fan will continue to run. To reset after “lock out” switch off the power supply to the system and wait 5 minutes. Then turn the power on. If repeated “lock out” occurs investigate the cause.

To shut down the heater, switch off the power supply to the system. Automatic control of the heater or a series of heaters may be achieved by incorporating thermostats, timeswitches, manual over-ride switches etc. in the electrical supply to the heater(s). It is essential to allow a delay of 15 seconds after switching off the system before attempting to restart.

If at any time after completion of the start up sequence loss of flame should occur, the control unit will attempt to reignite. If this is unsuccessful, “lock out” will occur.

Set burner gas pressure as follows: Switch off power supply to the heating system. Loosen the screw at the pressure test point on the combination gas valve and connect a ‘U’ tube manometer. Remove black cap from the pressure regulator screw. Start the heater and using a suitable screwdriver adjust the pressure regulator screw by turning the screw clockwise to increase the pressure or counter-clockwise to decrease the pressure. Set the pressure to the appropriate IN. W.C. setting refer to Table One selecting the correct heater description. Once set, switch off the power supply to the heater. Disconnect ‘U’ tube manometer and securely tighten screw in pressure test point.

Check the operation of the flame safeguard equipment as follows: With the heater running normally, switch off the gas supply at the shut off valve. The heater should attempt to relight and if the gas valve has been left off “lock out” should occur indicated by the “Power On” light only being illuminated and fan running.

Check the operation of the vacuum proving switch as follows: With the heater running normally, pull off the silicone rubber tube connecting the vacuum switch to the combustion chamber. Within one second the burner should shut off. Then replace the tube securely and observe that the heater proceeds to ignite in the normal way.

Replace the controls cover securing the five fixing screws.

B. SERVICE AND MAINTENANCE INSTRUCTIONS

B.1 SERVICING INSTRUCTIONS

Under normal working conditions, it is recommended that the AMBI-RAD heater be serviced annually. In exceptionally dirty or dusty conditions such as may occur in a foundry, more frequent servicing may be desirable. Servicing work should be carried out by a qualified gas service engineer.

⚠ WARNING: FIRE OR EXPLOSION HAZARD — Turn **OFF** gas and electrical supplies before performing Servicing and Maintenance procedures.

IMPORTANT:

- Never rest anything (especially ladders) against the heater.
- Unless otherwise instructed, reassemble components in reverse order of the disassembly.

ER Series
Ibl06 — p13

B.2 ROUTINE SERVICE

- A. FAN – Inspect the fan impeller and remove dust with a soft brush. Similarly remove any dust from the finger guard covering the secondary (cooling) impeller and the mesh aperture in the motor cover. Ensure that the impeller turns freely and that there is no excessive play in the bearings.
- B. EMITTER TUBE – Brush away any dust on the exterior of the emitter tube. Inspect the emitter tube internally by removing the burner control box as directed in D below. If there is any build up of dust or deposits, the tube should be cleaned internally. The emitter tube may be cleaned by use of an industrial vacuum cleaner with a long extension or a brush of the appropriate size and shape which is passed through the emitter tube. Replace the burner/control assemblies engaging them fully onto their tubes and secure by tightening the screws ensuring they are positioned squarely (i.e., with the air inlet cover plate facing upwards).
- C. REFLECTOR – The condition of the reflector should be noted and any necessary cleaning performed. The reflectors can be simply removed for cleaning by removing the reflector bolts securing them to the suspension brackets and sliding them out of the suspension brackets. The reflector can be cleaned with a soft cloth and detergent in water. A mild non abrasive metal polish may be used in cases of extreme discoloration.
- D. REMOVAL OF BURNER/CONTROL ASSEMBLY – Remove the burner/control assembly by disconnecting the gas and electrical supply (and fresh air inlet duct if fitted). Loosen the burner fixing screws and slide the assembly off the emitter tube.
- E. BURNER/ELECTRODE ASSEMBLY – Inspect the burner/electrode assembly by removing the six screws securing the combustion chamber

B.2 ROUTINE SERVICE (CONT.)

cover plate to top of control box, taking care not to damage the sealing gasket. Remove the burner head by unscrewing it from the injector taking care not to drop it onto the leads of the ignition electrodes. Replace the electrode assembly if it is not in good condition. The assembly is removed by removing the screws which attach it to the bracket on the front wall of the combustion chamber. The assembly is then lifted out of the combustion chamber and the cable disconnected. If the electrode assembly is in good order check the spark electrode gap, this should be .125 inches \pm .030 inches. Adjust the gap if necessary by bending the ground rod. Ensure the electrical connections are secure.

Inspect the injector and clean as necessary using a soft bristle brush. To remove or replace the injector, with the burner head removed, unscrew the injector from its carrier using a wrench, on the hexagon portion of its body. When replacing the injector ensure that it is fully tightened in its carrier (snug, not overtight).

Replace the burner head. Replace the combustion chamber top cover, renewing the rubber sealing gasket if this is not in good condition.

Inspect the burner fresh air inlet duct if fitted and ensure that it is free of any blockage or obstruction. Inspect the air inlet terminal and ensure this is not liable to obstruction.

Re-check the heater by following the procedure for check out and start up, taking care to check that the burner gas pressure is correctly set, and that the vacuum switch and flame safeguard equipment function correctly.

F. AUXILIARY CONTROLS – Check that auxiliary controls such as room thermostats, time switches, etc. function correctly and are set to operate at the desired temperatures. Ensure that the user is aware of the functions of the auxiliary controls and their correct settings. For most efficient operation of the heating system the time switch, if fitted, should be set to switch on normally between ¼ hour and 1 hour before commencement of occupancy of the building, depending on local conditions. The correct setting of the room thermostat can only be determined by experience in cold weather when it should be set to shut off the heaters when a comfortable level of warmth has been achieved. This setting will normally be several degrees below that which would be required with a convective heating system.

 **WARNING:** FIRE OR EXPLOSION HAZARD — Turn **OFF** gas and electrical supplies before performing any repair work.

ER Series, 1B107 —p14

B.3 REPLACEMENT OF COMPONENTS

- A. TO REPLACE ANY COMPONENTS IN THE BURNER/CONTROL ASSEMBLY – This assembly should be removed from the heater by disconnecting the gas and electrical supplies (also the fresh air intake duct if used). Loosen the bolts and slide the burner/control assembly from the emitter tube.
- B. TO REPLACE ELECTRODE ASSEMBLY – Remove top cover of combustion chamber by removing 6 screws. Remove the screws securing the electrode assembly and pull off the electrode cable connector. Reconnect the cable connector to the new electrode assembly and replace the assembly. Replace the cover plate and gasket. Spark electrode gap $.125 \pm .030$ ".
- C. TO REPLACE THE BURNER HEAD – Remove combustion chamber cover as in section B above. Unscrew burner head from injector. Screw on new burner head. Replace combustion chamber cover.
- D. TO REPLACE THE INJECTOR – Refer to Page 13, section E.
- E. TO REPLACE COMBINATION GAS VALVE – Remove combustion chamber cover as in paragraph B. Remove control housing cover. Remove burner head as in paragraph C. Unscrew the gas supply pipe entering the combination gas valve. Remove the electrical connections from the valve. Remove the 2 screws holding the gas valve. The combination gas valve can now be removed. Replace any defective component and reassemble using approved pipe joining compound on pipe threads.
- F. TO REPLACE THE BURNER/CONTROL UNIT – Remove the control housing cover. Disconnect the control module wiring harness from the burner control plug. Remove the gray ignition wire from control units spade connector. Remove the plastic retaining pins that secure the burner control unit to the side of the control housing. Remove the control module and replace with new control unit, reconnecting the retaining pins, wiring harness plug and ignition wire.
- G. TO REPLACE THE VACUUM SWITCH – Disconnect the plastic tube connection at the vacuum switch. Remove the black, yellow, and gray wires from the switches spade connectors. Remove the bolt and nut arrangement that holds the vacuum switch to the base of the control housing and remove the switch. Installing is the reversal of the above taking care to correctly reconnect the electrical wires and the plastic vacuum tube, see the "VACUUM SWITCH CONNECTION DETAILS".

B.4 USERS INSTRUCTION

Hand the Users Instructions to the user and explain how to operate the heater.

Leave the Installation and Servicing Instructions with the service maintenance engineer or manager for use on future service calls.

GAS VALVE TEST & ADJUSTMENT DETAIL

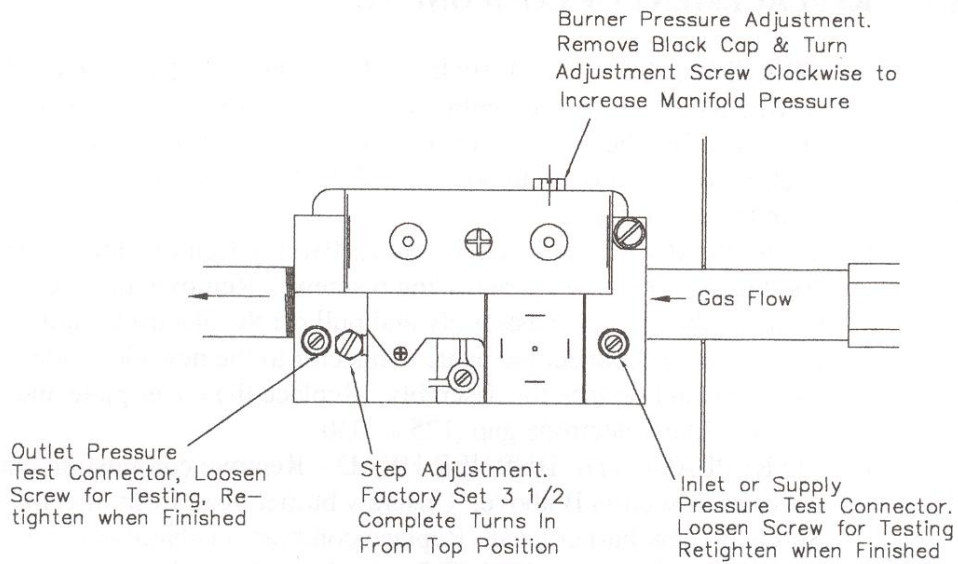

VACUUM SWITCH DETAIL

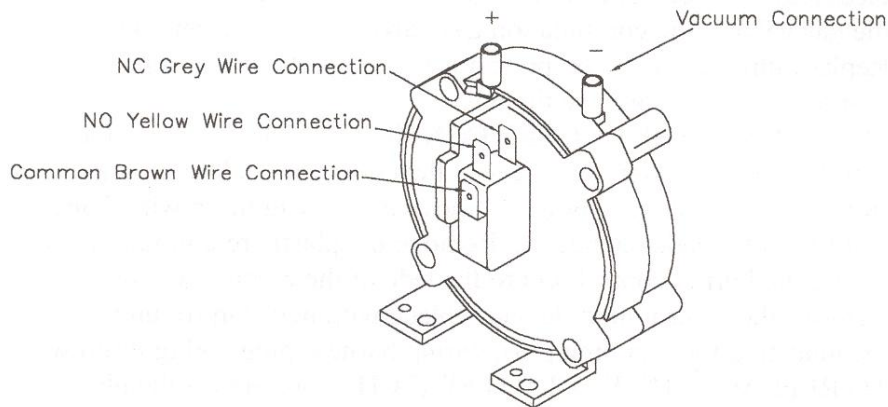

COMBUSTION TUBE SEAM LOCATION DETAIL

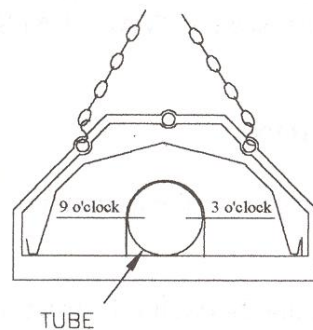

Combustion tube seam **must** be located below horizontal, below the 3 & 9 o'clock position.

USERS INSTRUCTIONS

AMBI-RAD TUBULAR RADIANT HEATERS

AMBI-RAD is the manufacturer of a series of tubular infrared heaters designed for overhead heating of industrial and commercial buildings. Individual heating units are suspended from the roof or mounted at an angle on the wall when inside buildings or horizontal when outside.

- IMPORTANT:**
- Never rest anything (especially ladders) against the heater.
 - This heater unit must only be installed by qualified craftsmen in accordance with the requirements of local and national codes.
 - This heater unit must be grounded in accordance with the National Electrical Code ANSI/NFPA No. 70.

ER Series
1b108 — p17

To Start The Heater

1. First ensure that the gas supply to each heater is turned on by opening main gas shut off valve.
2. Ensure that the settings of any time switch and thermostat are such that the heating system will be required to operated.
3. Switch on the electrical supply to the heater. The fan will start, the “Power On” light on the burner will illuminate and ignition commence.
4. Ignition will occur and the burner light, colored orange, will illuminate.
5. If ignition is unsuccessful the gas valve will close and the spark ignitor de-energize after approximately 10 seconds. For approximately 15 seconds the fan will purge the system then re-ignition will be attempted. After 3 attempts at ignition the control unit will “lock out”, the “power on” lamp will remain illuminated and the fan will continue to run. To reset after “lock out”, switch off the power supply to the heater and wait 5 minutes. Then turn the power on. If repeated “lock out” occurs investigate the cause.

To Switch Off The Heater

Switch off the electrical supply. The burner will shut off and the fan will stop.

Servicing

To ensure continued efficient and safe operation it is recommended that the heater be serviced regularly by a qualified person, e.g. every year in normal working conditions but in exceptionally dusty or polluted conditions more frequent servicing may be needed.

▲ WARNING: FIRE OR EXPLOSION HAZARD — Expansion of the radiant pipe occurs with each firing cycle causing the burner to move with respect to the gas line. This can result in a gas leak producing an unsafe condition. It is therefore essential to provide some flexibility in the final gas line connection — preferably by use of an approved armoured flexible connector or stainless steel expansion loop (see “SUGGESTED SERVICE CONNECTIONS” drawing in Appendix “A”).

ER Series:
1b104—p6

INSTALLATION INSTRUCTIONS FOR CORRUGATED FLEXIBLE STAINLESS STEEL HOSE ASSEMBLIES

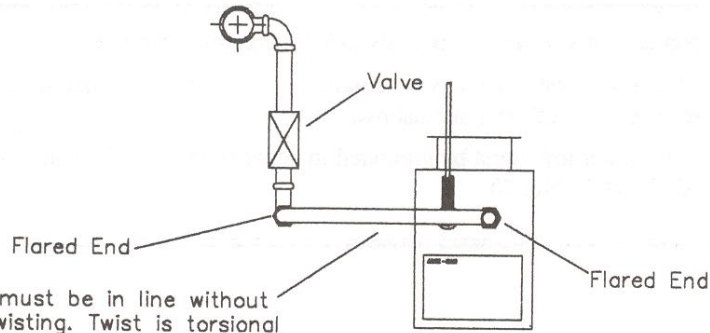

Note: Hose must be in line without torsion or twisting. Twist is torsional strain which is harmful to hose.

TYPICAL EXAMPLE AMBIRAD "ER" SERIES HEATERS

Note:
Do not over bend hoses. Elbows must be fitted to eliminate sharp bends near end fittings. Hose must be checked during annual heater service for any signs of deterioration, corrosion, or leakage, and replaced if any doubt.

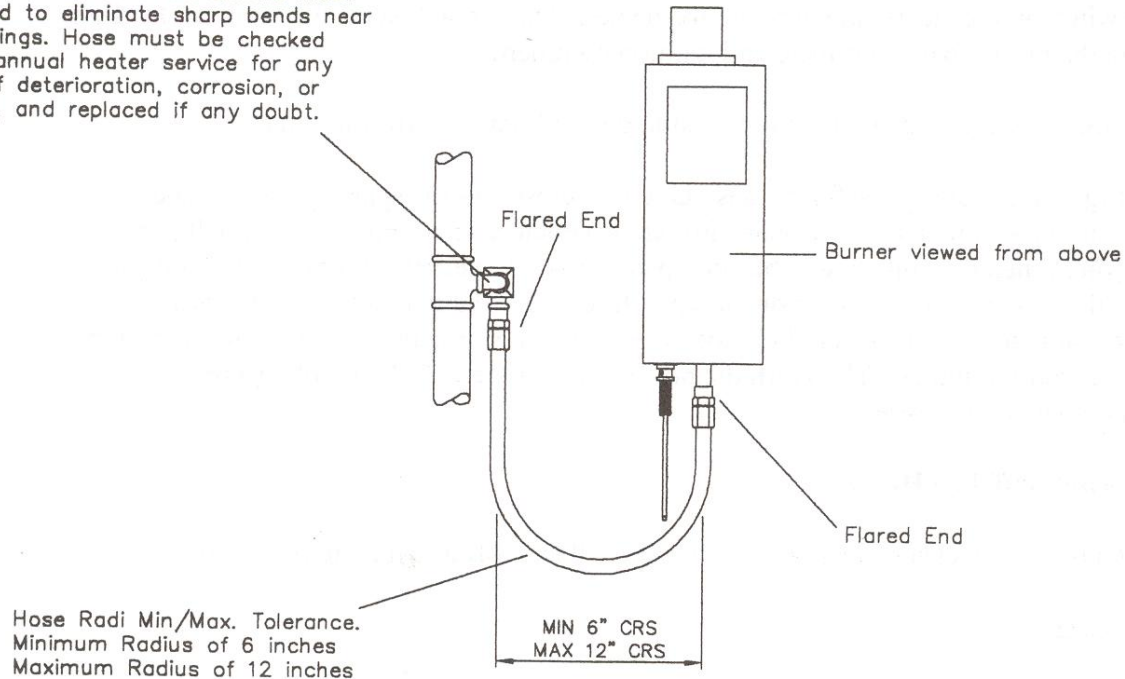

Hose Radi Min/Max. Tolerance.
Minimum Radius of 6 inches
Maximum Radius of 12 inches

AMBI-RAD.
Energy Efficient Heating Systems

AMBIRAD "ER" WIRING DETAIL FOR LINE & LOW VOLTAGE THERMOSTAT

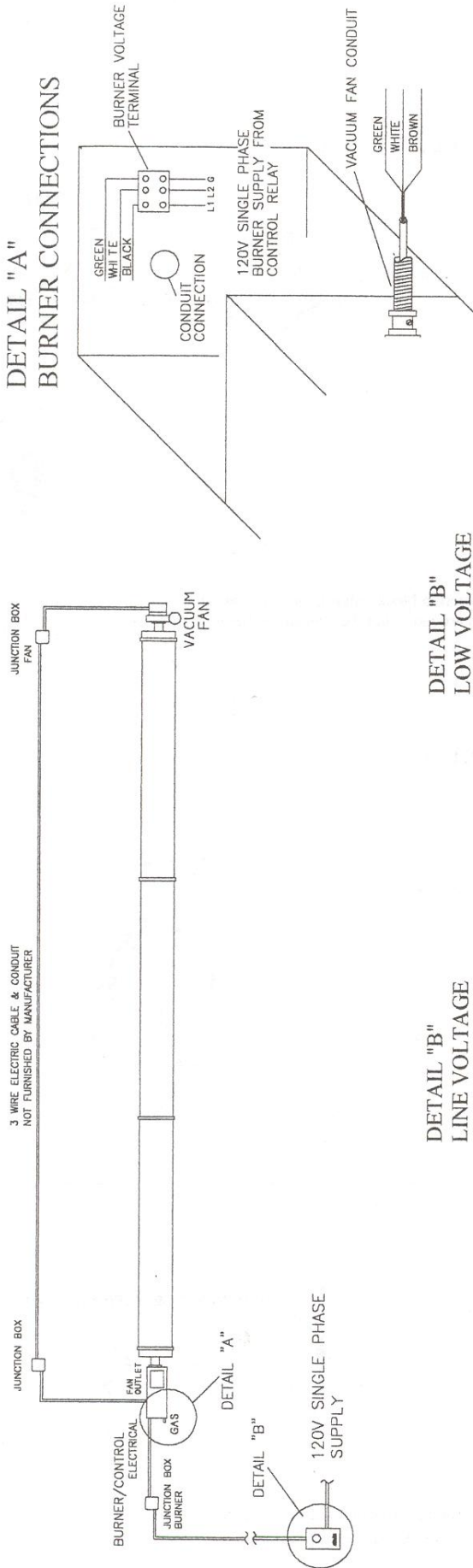

DETAIL "A"
BURNER CONNECTIONS

DETAIL "B"
LINE VOLTAGE THERMOSTAT

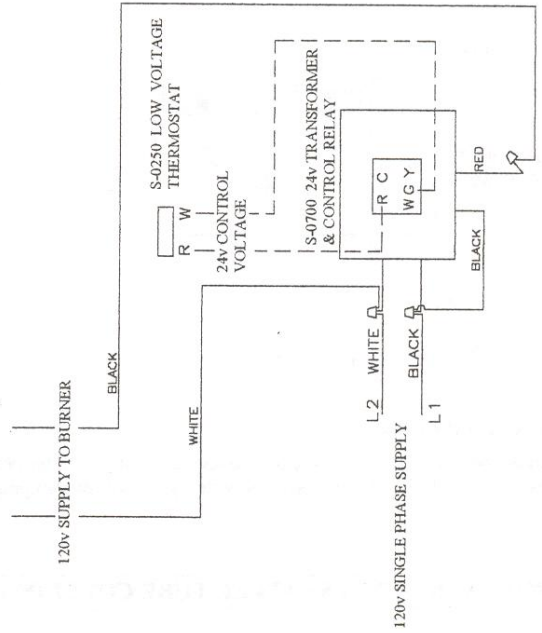

DETAIL "B"
LOW VOLTAGE THERMOSTAT & RELAY

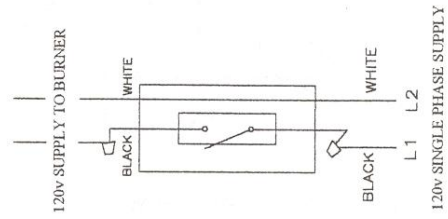

DETAIL "B"
LINE VOLTAGE THERMOSTAT

⚠ WARNING

Before making electrical connections, switch **OFF** the main electrical disconnect. There may be more than one disconnect switch. Lock out and tag switch with a suitable warning label. Electrical shock can cause personal injury or death.

ER Series; 1b105 — p8

TUBE COUPLING DETAIL

TYPICAL 3" TUBE COUPLING

BOLT TYPE BAND COUPLING USED TO CONNECT 3" RADIANT TUBES.

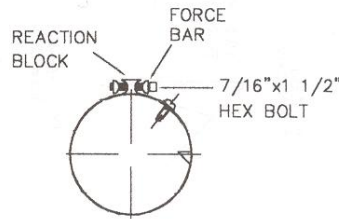
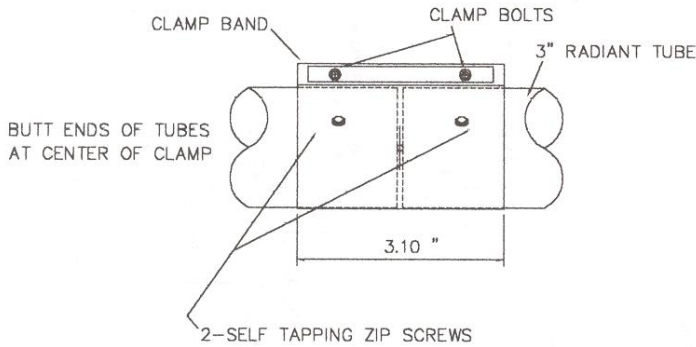

"IMPORTANT"

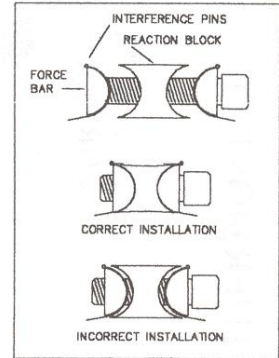

INSTALLATION INSTRUCTIONS

Alternately tighten the clamp bolts until the band comes in contact with the center reaction block (approx. 40-60ft.lbs. of static torque). The reaction block should be seated on the tube and the band stretched to provide a good seal & clamping load around both tubes. Secure tubes to the coupling with the self tapping zip screws.

TYPICAL 4" STAINLESS STEEL TUBE COUPLING

DRAW BAND COUPLING USED TO CONNECT 4" RADIANT TUBES.

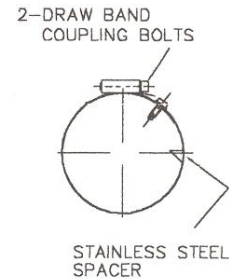
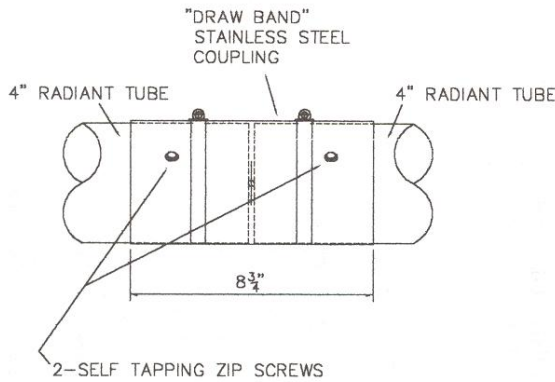

BURNER SUPPORT DETAIL

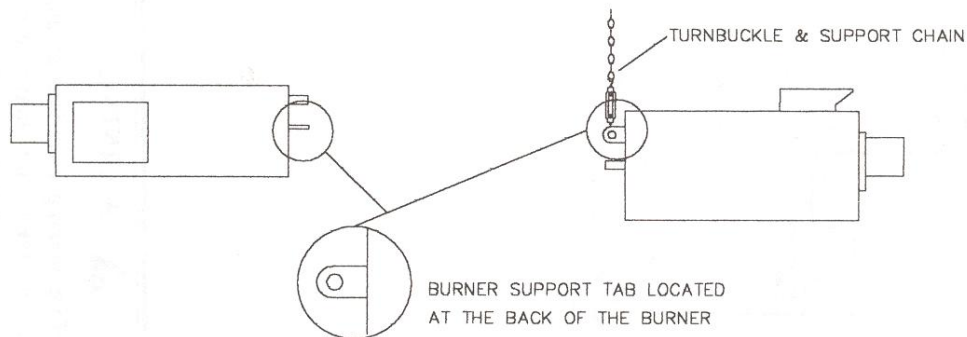

VERTICAL VENT REQUIREMENTS FOR INDIVIDUAL HEATER

"CATEGORY III TYPE VENT" FOR SINGLE OR DOUBLE WALL VENT PIPING

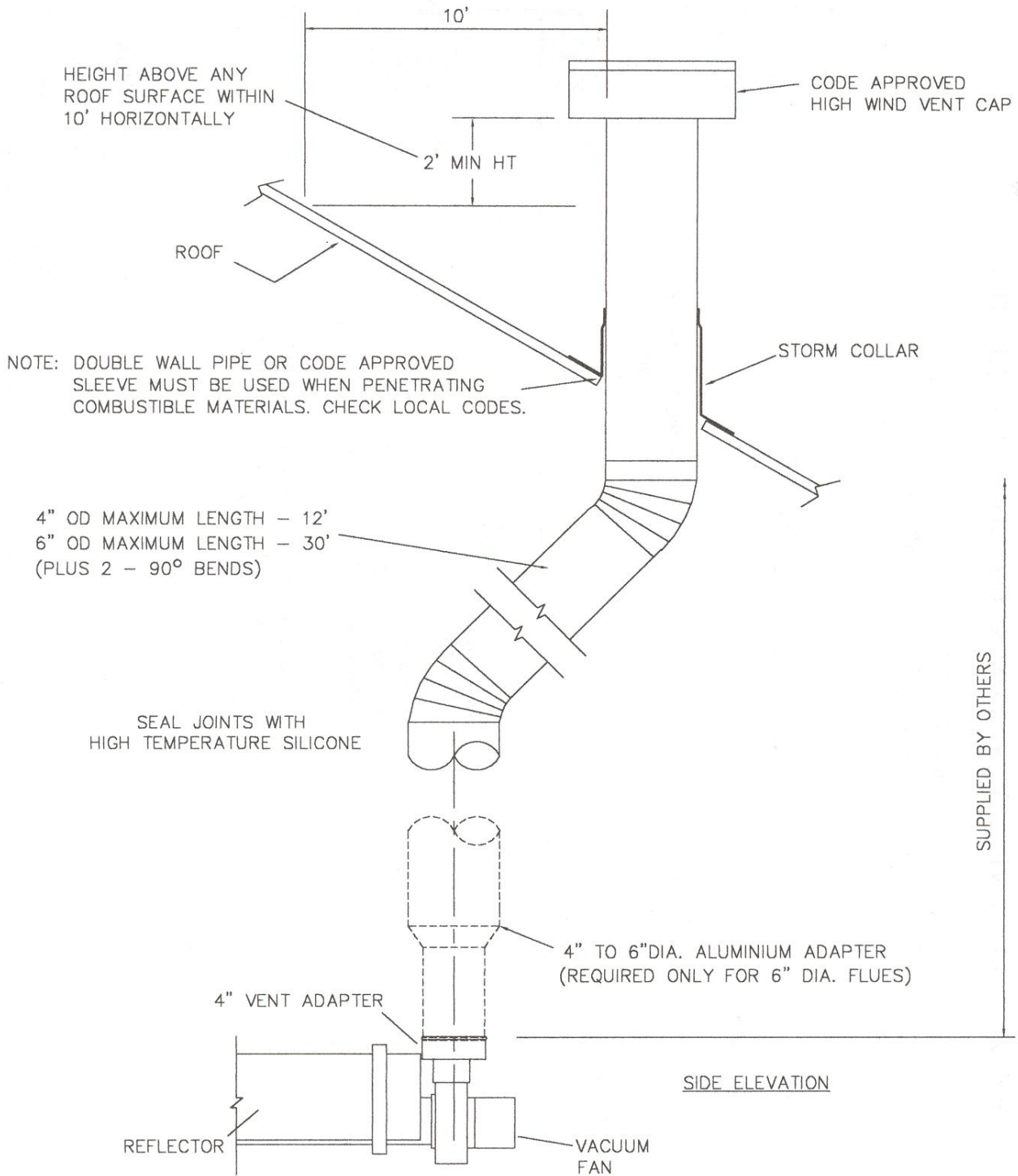

HORIZONTAL VENT REQUIREMENTS FOR INDIVIDUAL HEATER

"CATEGORY III TYPE VENT"
FOR SINGLE OR DOUBLE WALL VENT PIPING

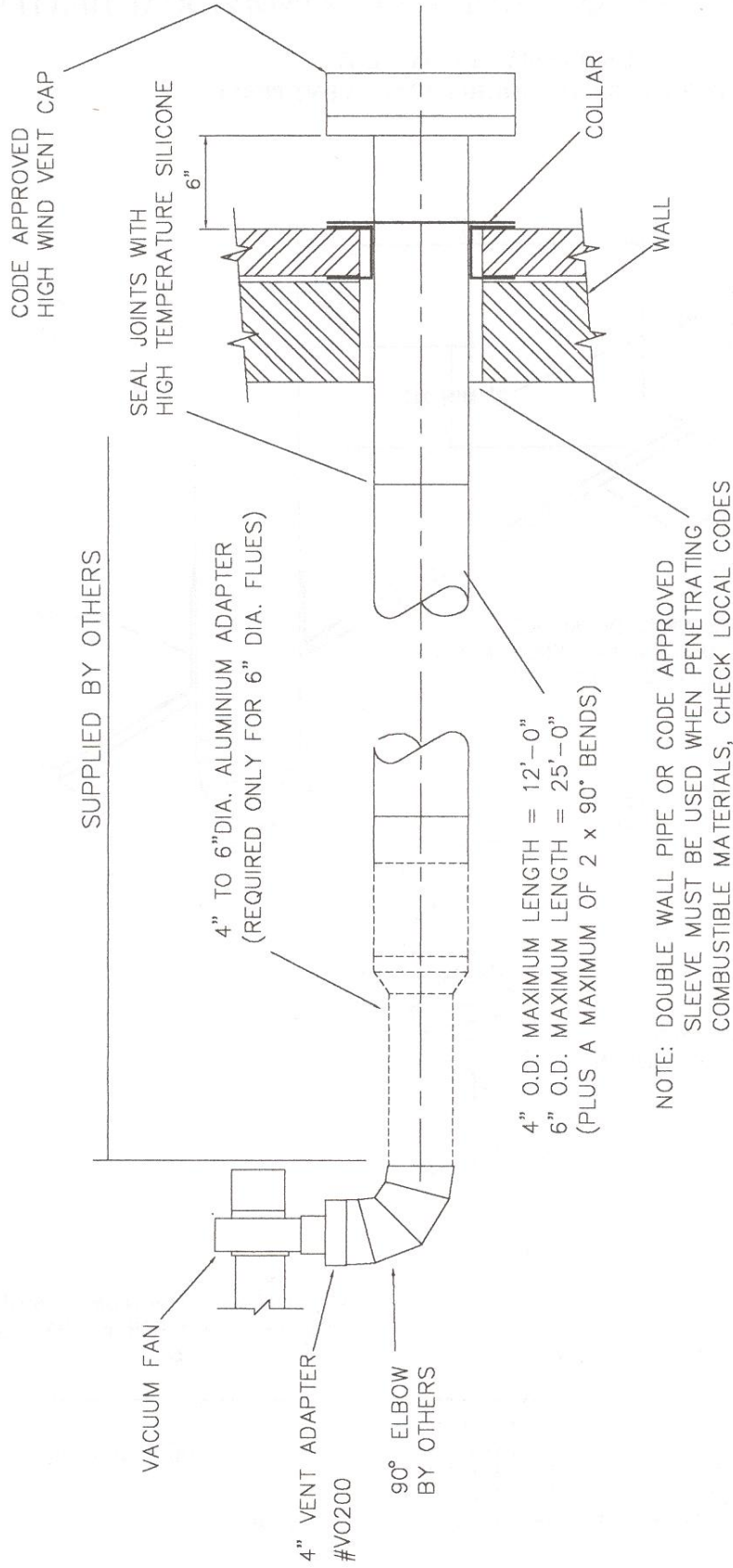

PLAN VIEW

TERMINAL PART NUMBERS	
V-0700	4" WALL TERMINAL
V-0800	6" WALL TERMINAL

OUTSIDE COMBUSTION AIR REQUIREMENTS, SIDE WALL APPLICATION

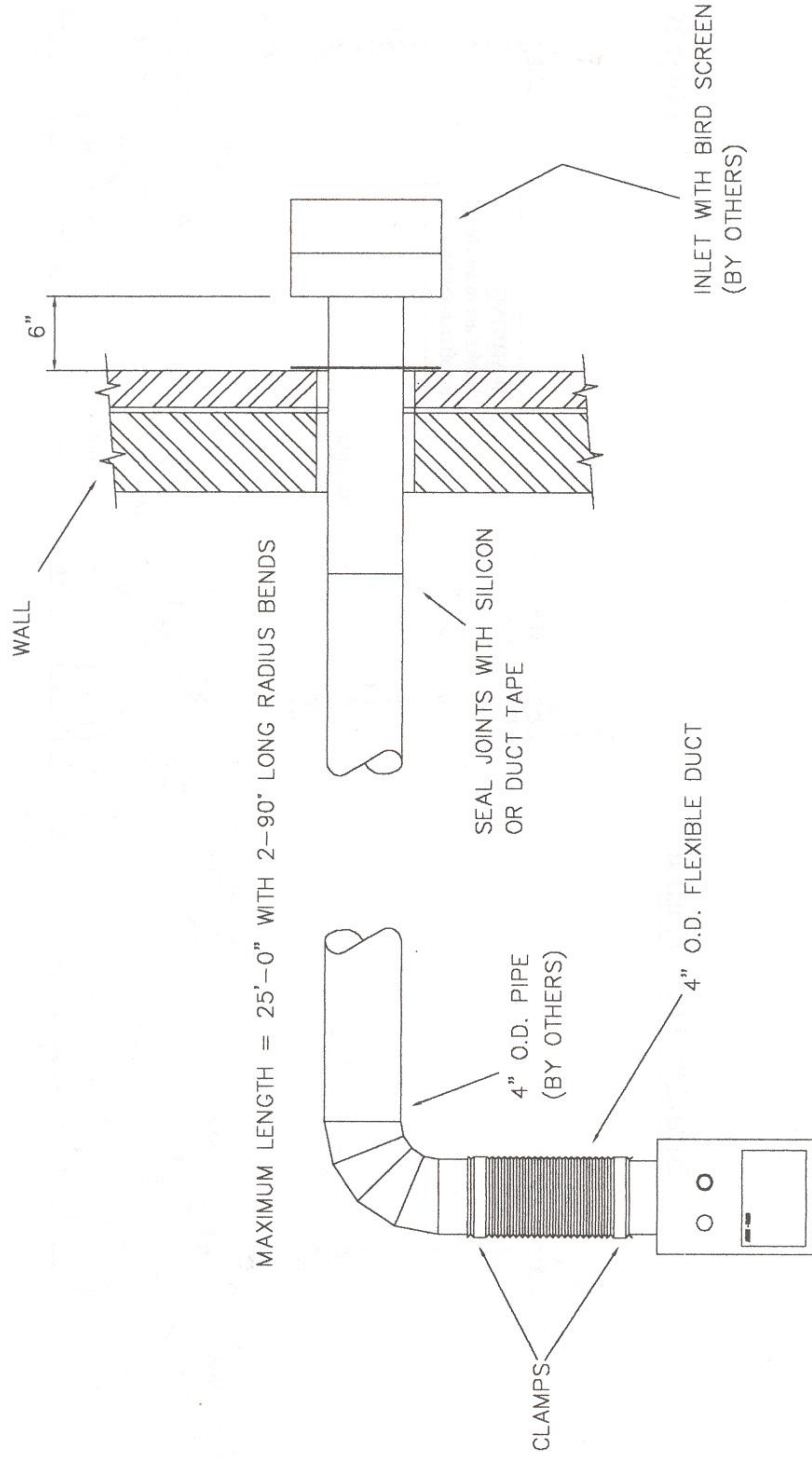

BURNER/CONTROL

COMBUSTION AIR KIT CUSTOM SELECTED BURNER ADAPTER REQUIRED

AMBRAD PART NUMBER	DESCRIPTION
CA-064	4"OD x 12" LONG FLEX HOSE & 2- 4" HOSE CLAMPS

NOTE: AIR INLET MUST BE LOCATED A MINIMUM OF 3' FROM ANY BUILDING EXHAUST OR FLUES

TYPICAL SUSPENSION DETAILS

Straight Tube Radiant

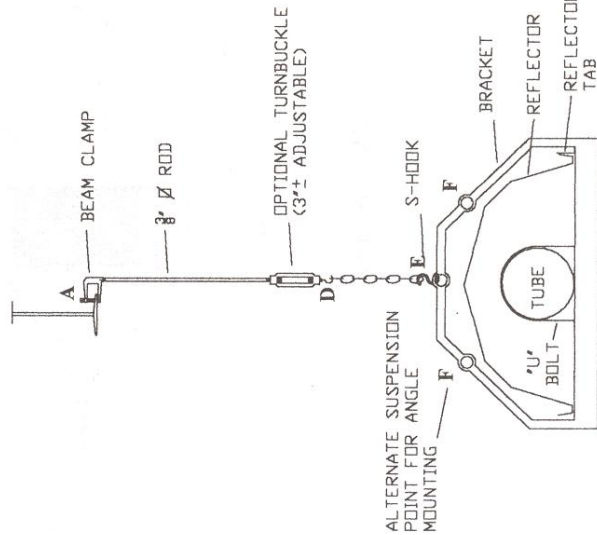

DROP ROD

"U" Tube Radiant

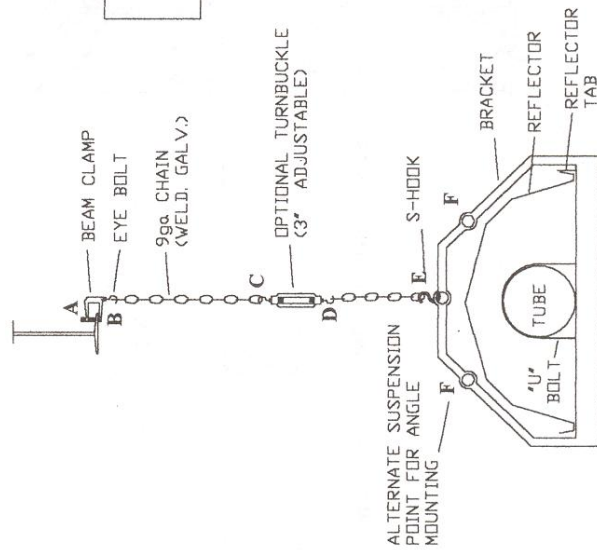

CHAIN

WARNING
Hooks are to be closed up after assembly

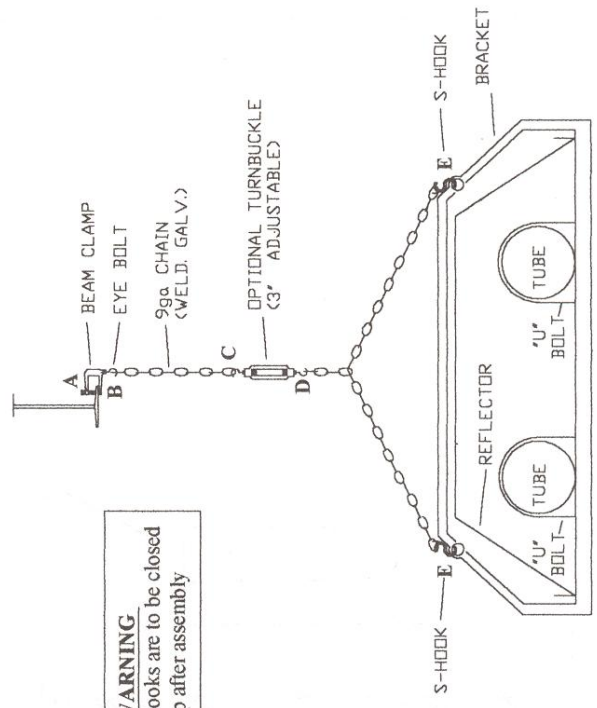

CHAIN

3" AMBIRAD GAS INFRARED HEATER ASSEMBLY DETAIL

"S20"

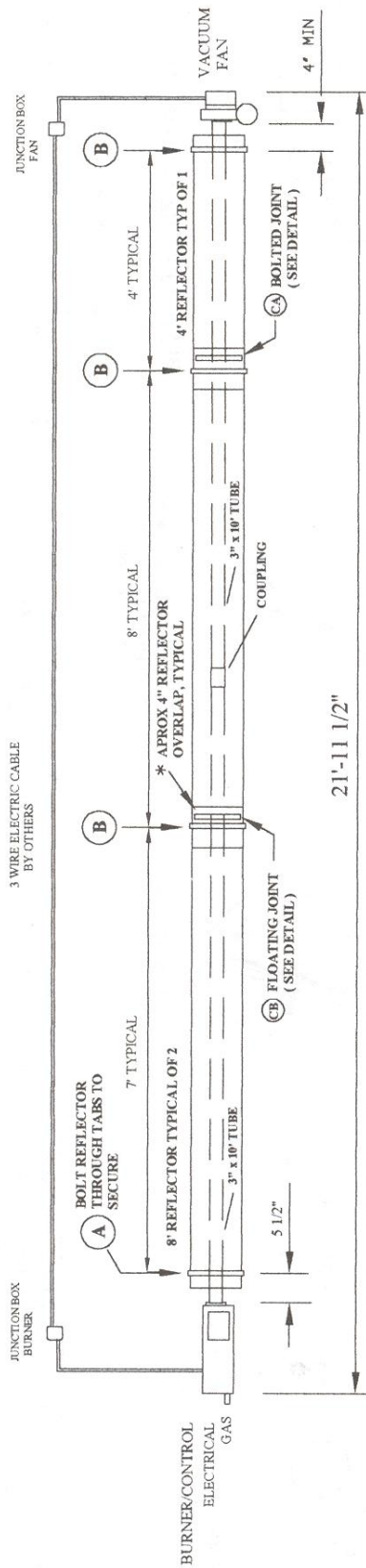

NOTE: THE FIRST TUBE SECTION MUST BE ALUMINIZED OR STAINLESS STEEL AND REQUIRES 2 HANGING POINTS, THE REMAINDER ONE EACH

* ALWAYS PLACE REFLECTOR ON TOP OF REFLECTOR SUPPORTED BY A BRACKET

- A** ALL A & B BRACKETS USED FOR SUSPENSION
- B**

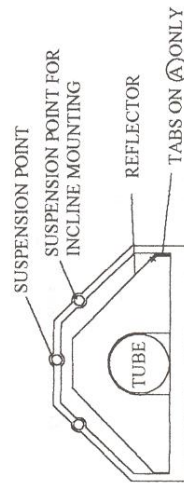

- A** BRACKET WITH TABS FOR BOLTING REFLECTOR
- B** BRACKET WITHOUT TABS

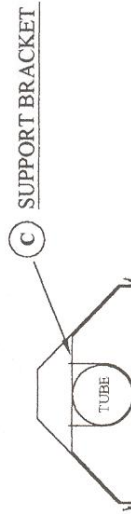

C SUPPORT BRACKET

CA BOLTED JOINT DETAIL

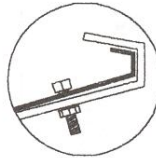

CB FLOATING JOINT DETAIL

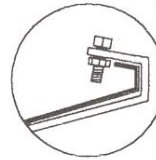

BOLT OVERLAPPED REFLECTORS TO BRACKET THROUGH HOLES

BOLT TO HOLD REFLECTOR DOWN INTO SUPPORT ALLOWING FOR EXPANSION AND CONTRACTION

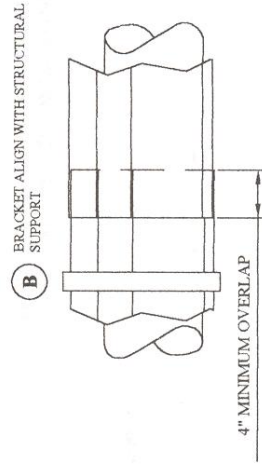

BURNER INSTALLATION DETAIL

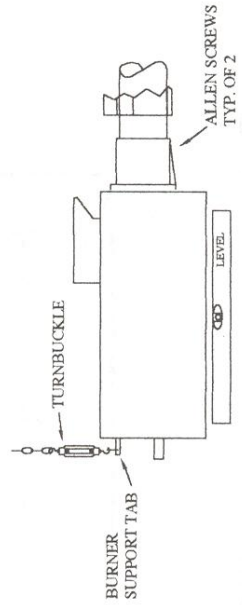

LEVEL THE BURNER USING THE TURNBUCKLE AT THE BURNER SUPPORT TAB BEFORE TIGHTENING THE BURNER HUB ALLEN SCREWS

MODEL NUMBER	BTU/HR	OPERATING GAS PRESSURE NATURAL GAS	LP GAS
SC/ER/GX12-S20	40,000	1.9"wc	6.7"wc
SC/ER/GX15-S20	50,000	3.0"wc	10.5"wc
SC/ER/GX18-S20	60,000	2.4"wc	6.7"wc
SC/ER/GX22-S20	75,000	3.8"wc	10.5"wc

SERIES	COMBUSTION TUBE	REMAINING TUBES	REFLECTORS
SC	ALUMINIZED	MILD STL	ALUMINUM
ER	ALUMINIZED	MILD STL	STAINLESS
GX	STAINLESS	STAINLESS	STAINLESS

TUBES COLOR CODED ON THE END TO IDENTIFY ITS COMPOSITION
 RED- STAINLESS YELLOW-ALUMINUM BLUE-MILD STEEL

3" AMBIRAD GAS INFRARED HEATER ASSEMBLY DETAIL

"S25"

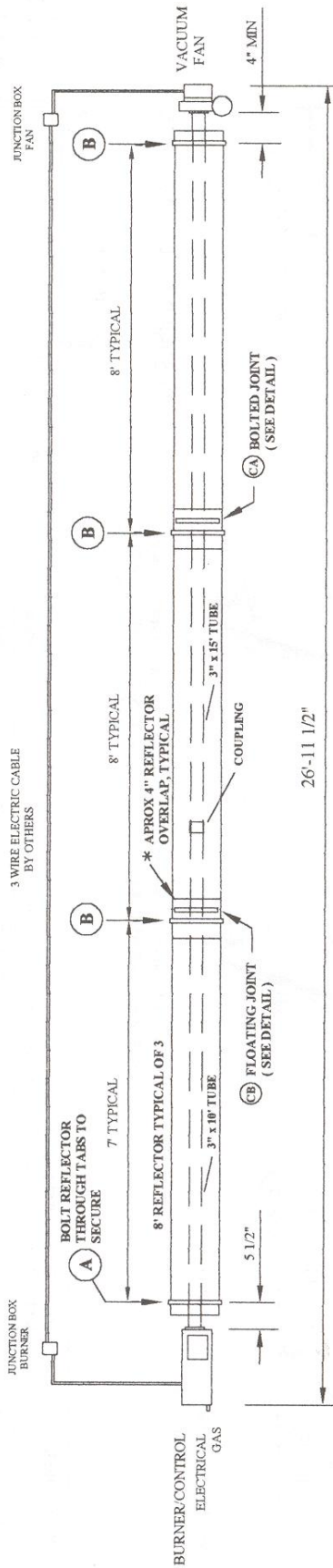

NOTE: THE FIRST TUBE SECTION MUST BE ALUMINIZED OR STAINLESS STEEL AND REQUIRES 2 HANGING POINTS, THE REMAINDER ONE EACH

* ALWAYS PLACE REFLECTOR ON TOP OF REFLECTOR SUPPORTED BY A BRACKET

- (A) ALL A & B BRACKETS USED FOR SUSPENSION
- (B)

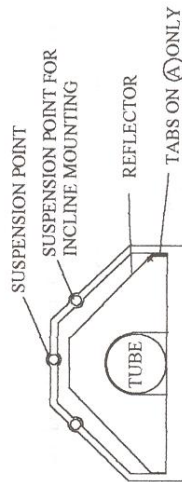

- (A) BRACKET WITH TABS FOR BOLTING REFLECTOR
- (B) BRACKET WITHOUT TABS

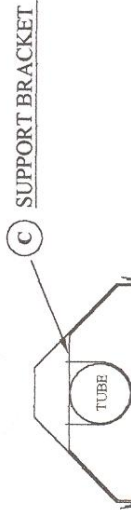

- (CA) BOLTED JOINT DETAIL
- (CB) FLOATING JOINT DETAIL

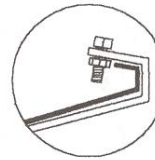
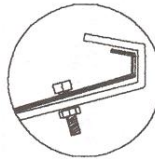

BOLT OVERLAPPED REFLECTORS TO BRACKET THROUGH HOLES

BOLT TO HOLD REFLECTOR DOWN INTO SUPPORT ALLOWING FOR EXPANSION AND CONTRACTION

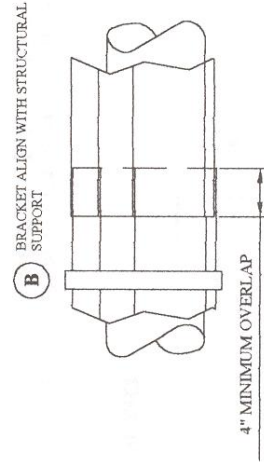

BURNER INSTALLATION DETAIL

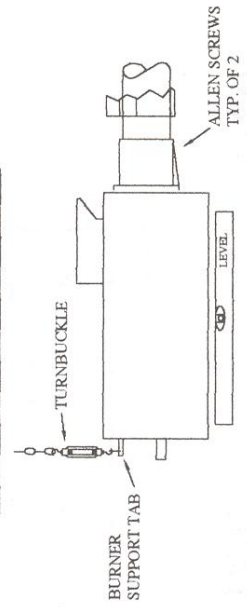

LEVEL THE BURNER USING THE TURNBUCKLE AT THE BURNER SUPPORT TAB BEFORE TIGHTENING THE BURNER HUB ALLEN SCREWS

MODEL NUMBER	BTU/HR	OPERATING GAS PRESSURE NATURAL GAS LP GAS	COMBUSTION TUBE	REMAINING TUBES	REFLECTORS
SC/ER/GX12-S25	40,000	1.9"wc 6.7"wc	ALUMINIZED	MILD STL.	ALUMINUM
SC/ER/GX15-S25	50,000	3.0"wc 10.5"wc	ALUMINIZED	MILD STL.	STAINLESS
SC/ER/GX18-S25	60,000	2.4"wc 6.7"wc	STAINLESS	STAINLESS	STAINLESS
SC/ER/GX22-S25	75,000	3.8"wc 10.5"wc	STAINLESS	STAINLESS	STAINLESS

TUBES COLOR CODED ON THE END TO IDENTIFY ITS COMPOSITION
 RED-STAINLESS YELLOW-ALUMINUM BLUE-MILD STEEL

3" AMBIRAD GAS INFRARED HEATER ASSEMBLY DETAIL "S30"

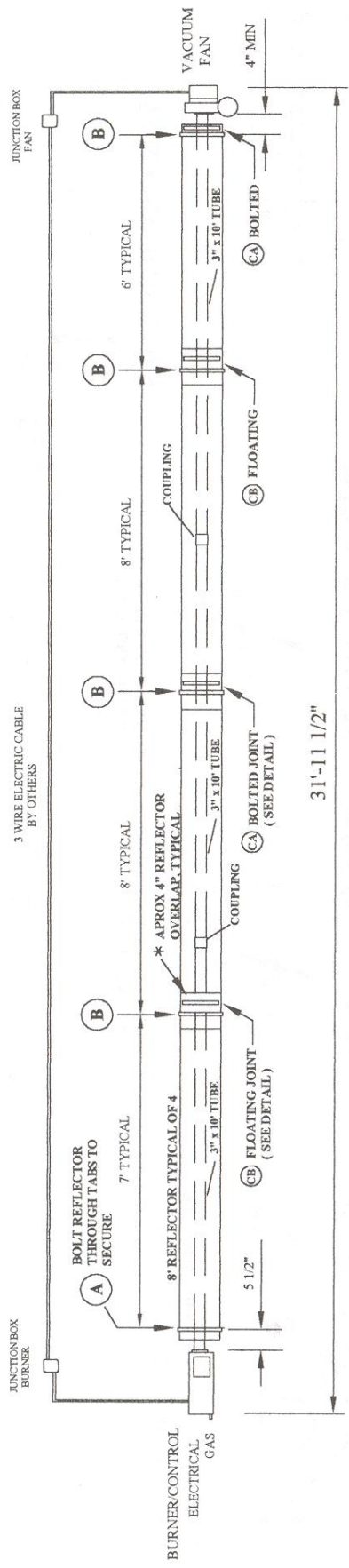

NOTE: THE FIRST TUBE SECTION MUST BE ALUMINIZED OR STAINLESS STEEL AND REQUIRES 2 HANGING POINTS, THE REMAINDER ONE EACH

* ALWAYS PLACE REFLECTOR ON TOP OF REFLECTOR SUPPORTED BY A BRACKET

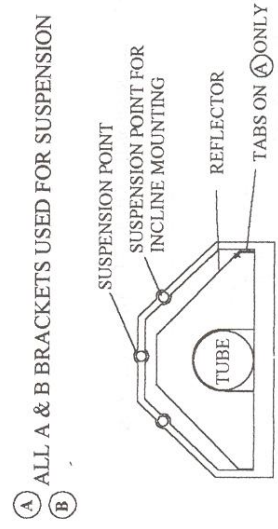

- (A) BRACKET WITH TABS FOR BOLTING REFLECTOR
- (B) BRACKET WITHOUT TABS

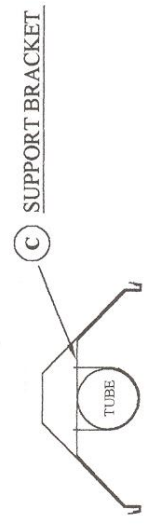

- (A) ALL A & B BRACKETS USED FOR SUSPENSION
- (B)

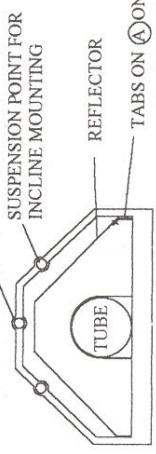

- (CA) BOLTED JOINT DETAIL
- (CB) FLOATING JOINT DETAIL

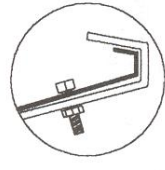

BOLT OVERLAPPED REFLECTORS TO BRACKET THROUGH HOLES

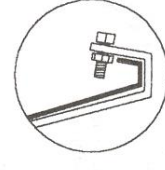

- (CB) FLOATING JOINT DETAIL

BOLT TO HOLD REFLECTOR DOWN INTO SUPPORT ALLOWING FOR EXPANSION AND CONTRACTION

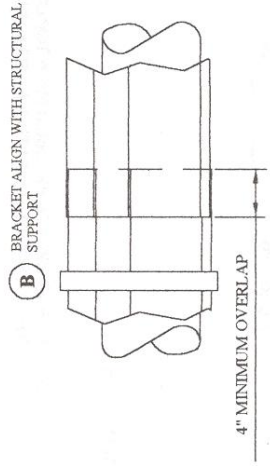

- (B) BRACKET ALIGN WITH STRUCTURAL SUPPORT

BURNER INSTALLATION DETAIL

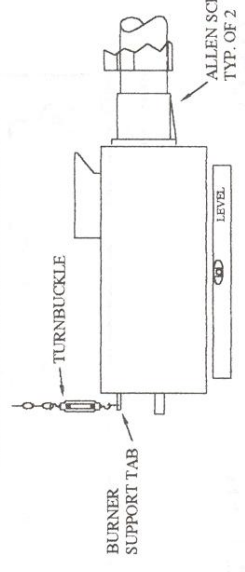

LEVEL THE BURNER USING THE TURNBUCKLE AT THE BURNER SUPPORT TAB BEFORE TIGHTENING THE BURNER HUB ALLEN SCREWS

SERIES	COMBUSTION TUBE	REMAINING TUBES	REFLECTORS
SC	ALUMINIZED	MILD STL.	ALUMINUM
ER	ALUMINIZED	MILD STL.	STAINLESS
GX	STAINLESS	STAINLESS	STAINLESS

TUBES COLOR CODED ON THE END TO IDENTIFY ITS COMPOSITION
 RED- STAINLESS YELLOW-ALUMINUM BLUE-MILD STEEL

MODEL NUMBER	BTU/HR	OPERATING GAS PRESSURE	NATURAL GAS	LP GAS
SC/ER/GX12-S30	40,000	1.9"wc	6.7"wc	
SC/ER/GX15-S30	50,000	3.0"wc	10.5"wc	
SC/ER/GX18-S30	60,000	2.4"wc	6.7"wc	
SC/ER/GX22-S30	75,000	3.8"wc	10.5"wc	

3" AMBIRAD GAS INFRARED HEATER ASSEMBLY DETAIL

"S40"

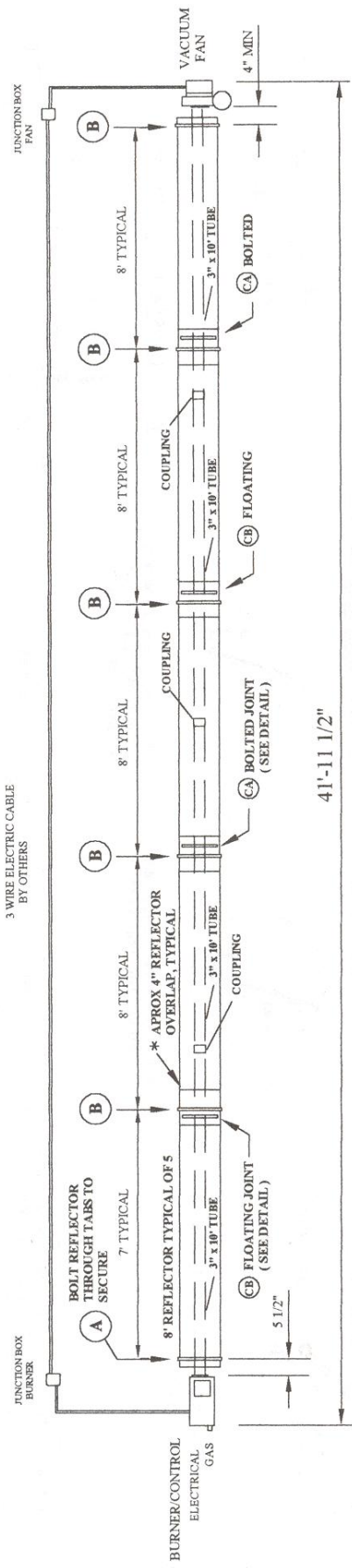

NOTE: THE FIRST TUBE SECTION MUST BE ALUMINIZED OR STAINLESS STEEL AND REQUIRES 2 HANGING POINTS, THE REMAINDER ONE EACH

* ALWAYS PLACE REFLECTOR ON TOP OF REFLECTOR SUPPORTED BY A BRACKET

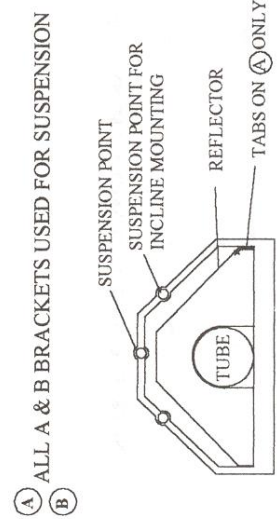
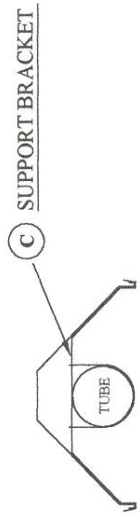

- (A) BRACKET WITH TABS FOR SUSPENSION
- (B) BRACKET WITHOUT TABS

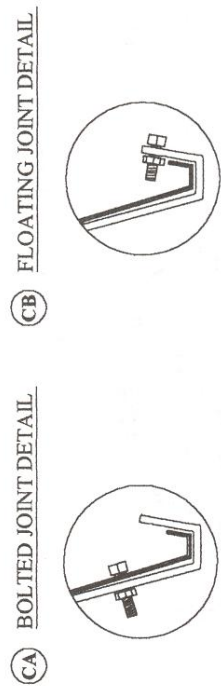

BOLT OVERLAPPED REFLECTORS TO BRACKET THROUGH HOLES

BOLT TO HOLD REFLECTOR DOWN INTO SUPPORT ALLOWING FOR EXPANSION AND CONTRACTION

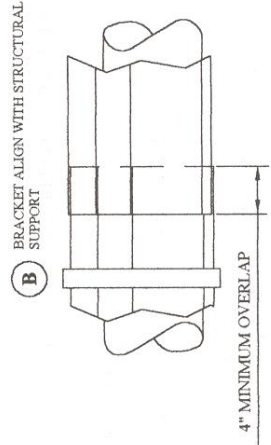

BURNER INSTALLATION DETAIL

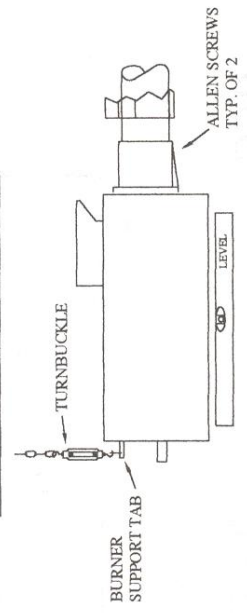

LEVEL THE BURNER USING THE TURNBUCKLE AT THE BURNER SUPPORT TAB BEFORE TIGHTENING THE BURNER HUB ALLEN SCREWS

SERIES	COMBUSTION TUBE	REMAINING TUBES	REFLECTORS
SC	ALUMINIZED	MILD STL.	ALUMINUM
ER	ALUMINIZED	MILD STL.	STAINLESS
GX	STAINLESS	STAINLESS	STAINLESS

TUBES COLOR CODED ON THE END TO IDENTIFY ITS COMPOSITION
 RED-STAINLESS YELLOW-ALUMINUM BLUE-MILD STEEL

MODEL NUMBER	BTU/HR	OPERATING GAS PRESSURE
		NATURAL GAS LP GAS
SC/ER/GX18-S40	60,000	2.4"wc 6.7"wc
SC/ER/GX22-S40	75,000	3.8"wc 10.5"wc

4" AMBIRAD GAS INFRARED HEATER ASSEMBLY DETAIL "S40"

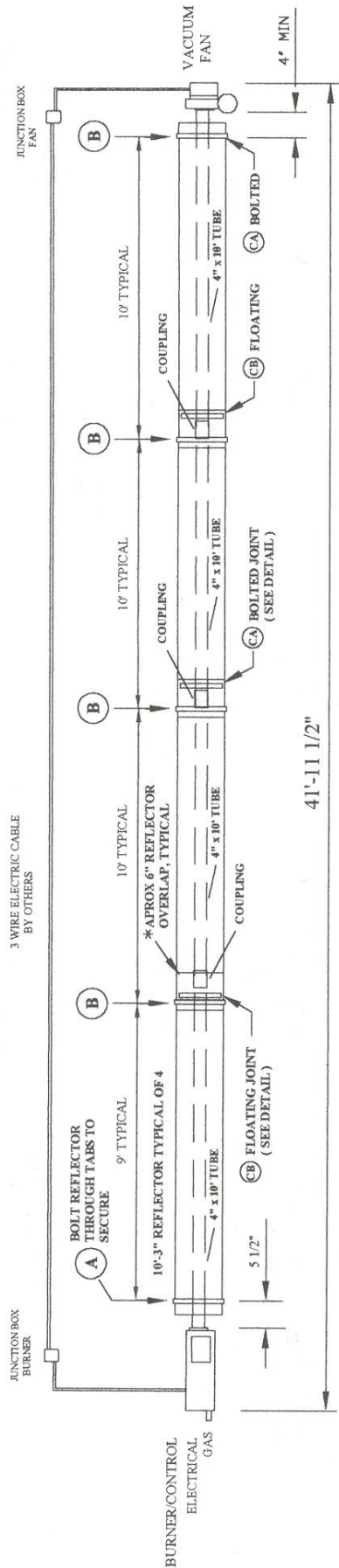

NOTE: THE FIRST TUBE SECTION MUST BE ALUMINIZED OR STAINLESS STEEL AND REQUIRES 2 HANGING POINTS, THE REMAINDER ONE EACH

* ALWAYS PLACE REFLECTOR ON TOP OF REFLECTOR SUPPORTED BY A BRACKET

- (A) ALL A & B BRACKETS USED FOR SUSPENSION
- (B) BRACKET WITHOUT TABS

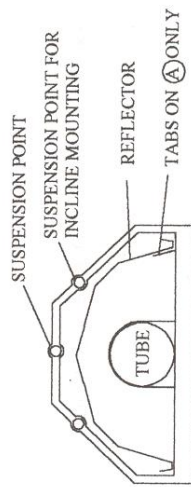

- (A) BRACKET WITH TABS FOR BOLTING REFLECTOR
- (B) BRACKET WITHOUT TABS

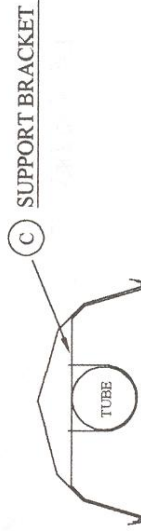

- (CA) BOLTED JOINT DETAIL
- (CB) FLOATING JOINT DETAIL



BOLT OVERLAPPED REFLECTORS TO BRACKET THROUGH HOLES

BOLT TO HOLD REFLECTOR DOWN INTO SUPPORT ALLOWING FOR EXPANSION AND CONTRACTION

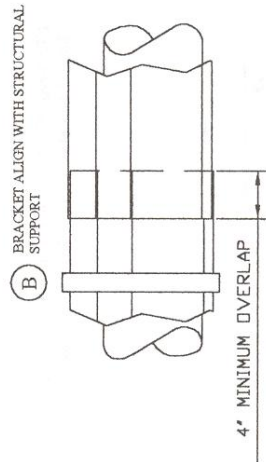

BURNER INSTALLATION DETAIL

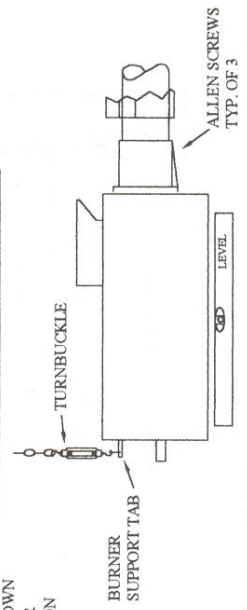

LEVEL THE BURNER USING THE TURNBUCKLE AT THE BURNER SUPPORT TAB BEFORE TIGHTENING THE BURNER HUB ALLEN SCREWS

SERIES	COMBUSTION TUBE	REMAINING TUBES	REFLECTORS
SC	ALUMINIZED	MILD STL.	ALUMINUM
ER	ALUMINIZED	MILD STL.	STAINLESS
GX	STAINLESS	STAINLESS	STAINLESS

TUBES COLOR CODED ON THE END TO IDENTIFY ITS COMPOSITION
 RED- STAINLESS YELLOW- ALUMINUM BLUE- MILD STEEL

MODEL NUMBER	BTU/HR	OPERATING GAS PRESSURE	NATURAL GAS	LP GAS
SC/ER/GX29-S40	100,000	4.9"wc	10.0"wc	
SC/ER/GX38-S40	130,000	4.9"wc	10.0"wc	
SC/ER/GX44-S40	150,000	4.6"wc	10.0"wc	

4" AMBIRAD GAS INFRARED HEATER ASSEMBLY DETAIL

"S50"

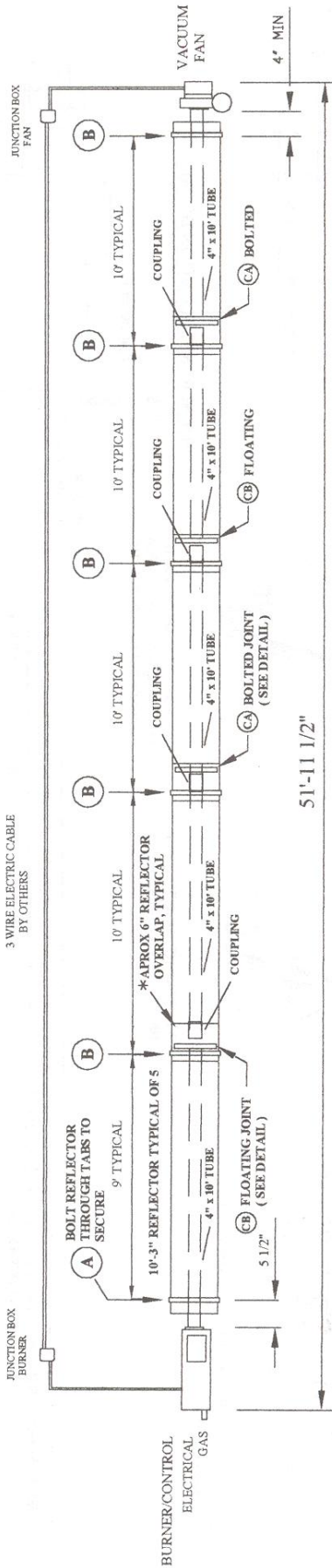

NOTE: THE FIRST TUBE SECTION MUST BE ALUMINIZED OR STAINLESS STEEL AND REQUIRES 2 HANGING POINTS, THE REMAINDER ONE EACH

* ALWAYS PLACE REFLECTOR ON TOP OF REFLECTOR SUPPORTED BY A BRACKET

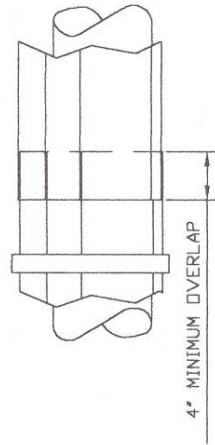
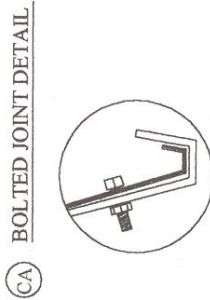
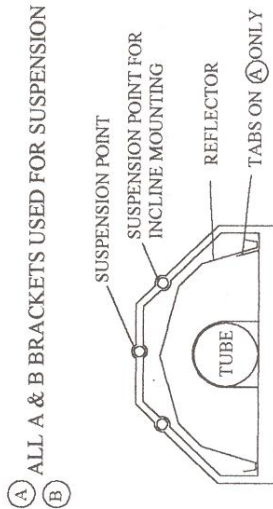

- (A) BRACKET WITH TABS FOR BOLTING REFLECTOR
- (B) BRACKET WITHOUT TABS

BOLT OVERLAPPED REFLECTORS TO BRACKET THROUGH HOLES

BOLT TO HOLD REFLECTOR DOWN INTO SUPPORT ALLOWING FOR EXPANSION AND CONTRACTION

BURNER INSTALLATION DETAIL

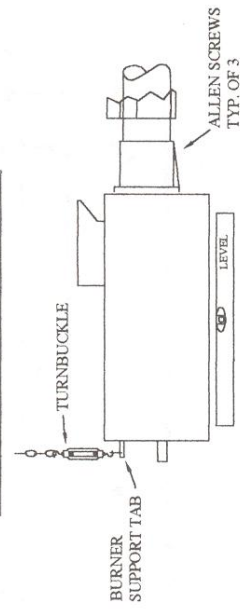

LEVEL THE BURNER USING THE TURNBUCKLE AT THE BURNER SUPPORT TAB BEFORE TIGHTENING THE BURNER HUB ALLEN SCREWS

SERIES	COMBUSTION TUBE	REMAINING TUBES	REFLECTORS
SC	ALUMINIZED	MILD STL.	ALUMINUM
ER	ALUMINIZED	MILD STL.	STAINLESS
GX	STAINLESS	STAINLESS	STAINLESS

TUBES COLOR CODED ON THE END TO IDENTIFY ITS COMPOSITION
 RED-STAINLESS YELLOW-ALUMINUM BLUE-MILD STEEL

MODEL NUMBER	BTU/HR	OPERATING GAS PRESSURE
NATURAL GAS LP GAS		
SC/ER/GX29-S50	100,000	4.9"wc 10.0"wc
SC/ER/GX38-S50	130,000	4.9"wc 10.0"wc
SC/ER/GX44-S50	150,000	4.6"wc 10.0"wc

4" AMBIRAD GAS INFRARED HEATER ASSEMBLY DETAIL

"S60"

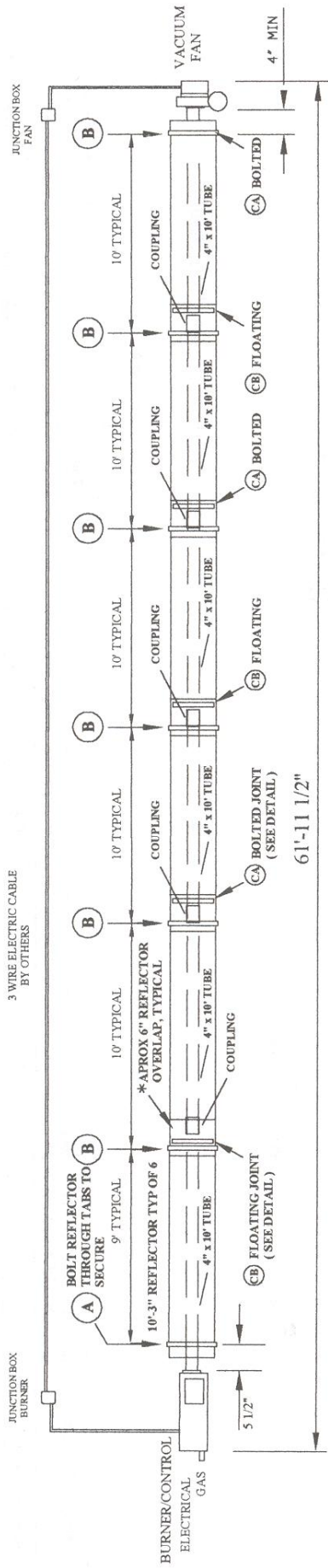

NOTE: THE FIRST TUBE SECTION MUST BE ALUMINIZED OR STAINLESS STEEL AND REQUIRES 2 HANGING POINTS, THE REMAINDER ONE EACH

* ALWAYS PLACE REFLECTOR ON TOP OF REFLECTOR SUPPORTED BY A BRACKET

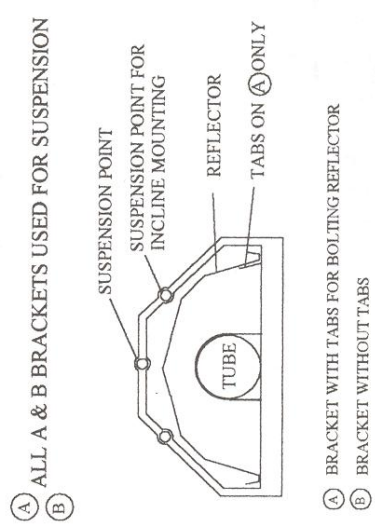

- (A) ALL A & B BRACKETS USED FOR SUSPENSION
- (B) SUSPENSION POINT FOR INCLINE MOUNTING
- (C) SUPPORT BRACKET
- (CA) BRACKET WITH TABS FOR BOLTING REFLECTOR
- (CB) BRACKET WITHOUT TABS

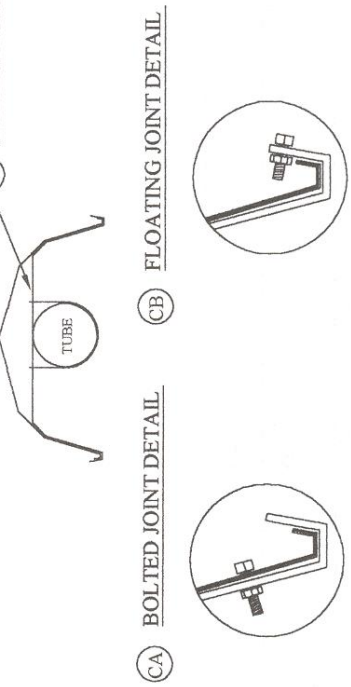

- (CA) BOLTED JOINT DETAIL
- (CB) FLOATING JOINT DETAIL
- (C) SUPPORT BRACKET

BOLT TO HOLD REFLECTOR DOWN INTO SUPPORT ALLOWING FOR EXPANSION AND CONTRACTION

BOLT TO OVERLAPPED REFLECTORS TO BRACKET THROUGH HOLES

BURNER INSTALLATION DETAIL

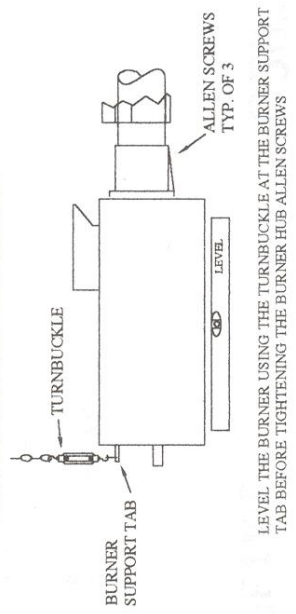

LEVEL THE BURNER USING THE TURNBUCKLE AT THE BURNER SUPPORT TAB BEFORE TIGHTENING THE BURNER HUB ALLEN SCREWS

SERIES	COMBUSTION TUBE	REMAINING TUBES	REFLECTORS
SC	ALUMINIZED	MILD STL.	ALUMINUM
ER	ALUMINIZED	MILD STL.	STAINLESS
GX	STAINLESS	STAINLESS	STAINLESS

TUBES COLOR CODED ON THE END TO IDENTIFY ITS COMPOSITION
 RED- STAINLESS YELLOW- ALUMINUM BLUE- MILD STEEL

MODEL NUMBER	BTU/HR	OPERATING GAS PRESSURE	NATURAL GAS	LP GAS
SC/ER/GX29-S60	100,000	4.9"wc	10.0"wc	
SC/ER/GX38-S60	130,000	4.9"wc	10.0"wc	
SC/ER/GX44-S60	150,000	4.6"wc	10.0"wc	

3" AMBIRAD GAS INFRARED HEATER ASSEMBLY DETAIL

"U20"

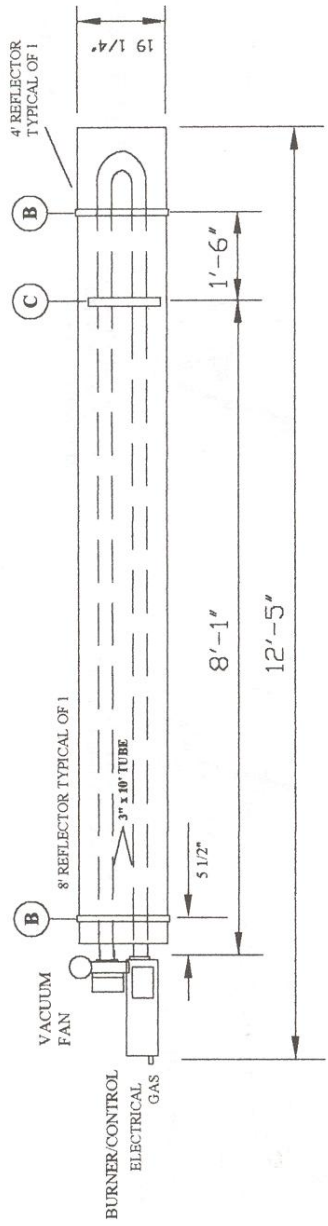

(B) ALL B BRACKETS USED FOR SUSPENSION

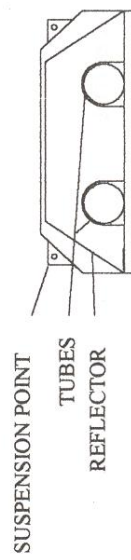

(B) BRACKET WITHOUT TABS



(C) REFLECTOR SUPPORT BRACKET

BURNER INSTALLATION DETAIL

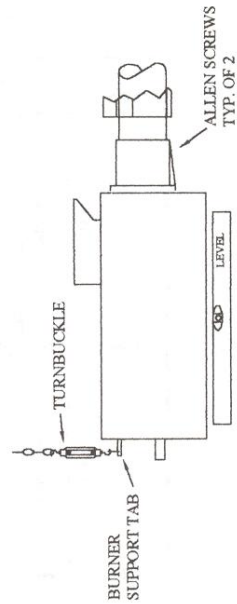

LEVEL THE BURNER USING THE TURNBUCKLE AT THE BURNER SUPPORT TAB BEFORE TIGHTENING THE BURNER HUB ALLEN SCREWS

SERIES	COMBUSTION TUBE	REMAINING TUBES	REFLECTORS
SC	ALUMINIZED	MILD STL.	ALUMINUM
ER	ALUMINIZED	MILD STL.	STAINLESS
GX	STAINLESS	STAINLESS	STAINLESS

TUBES COLOR CODED ON THE END TO IDENTIFY ITS COMPOSITION
 RED-STAINLESS YELLOW-ALUMINUM BLUE-MILD STEEL

MODEL NUMBER	BTU/HR	OPERATING GAS PRESSURE	NATURAL GAS	LP GAS
SC/ER/GX12-U20	40,000	1.9"wc	6.7"wc	
SC/ER/GX15-U20	50,000	3.0"wc	10.5"wc	
SC/ER/GX18-U20	60,000	2.4"wc	6.7"wc	
SC/ER/GX22-U20	75,000	3.8"wc	10.5"wc	

8/02

3" AMBIRAD GAS INFRARED HEATER ASSEMBLY DETAIL "U30"

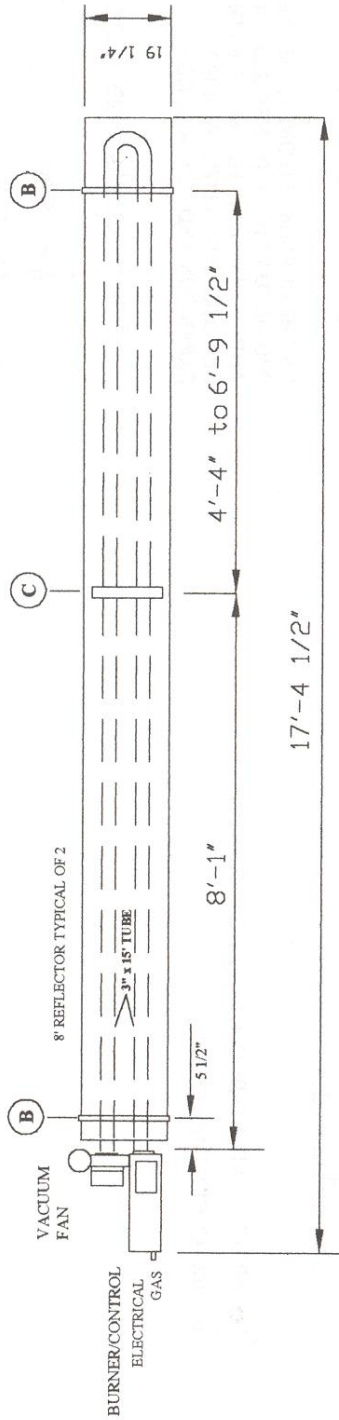

(B) ALL B BRACKETS USED FOR SUSPENSION

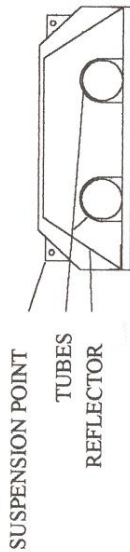

(B) BRACKET WITHOUT TABS

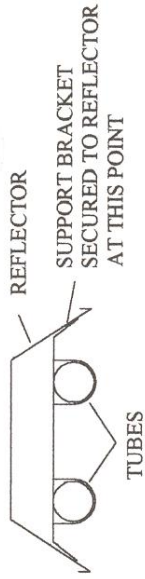

(C) REFLECTOR SUPPORT BRACKET

BURNER INSTALLATION DETAIL

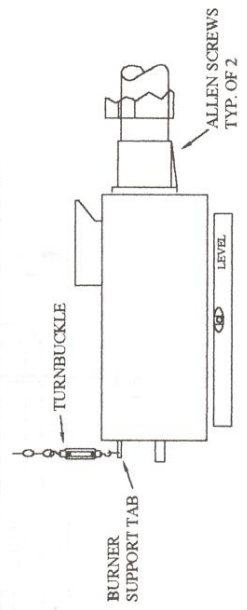

SERIES	COMBUSTION TUBE	REMAINING TUBES	REFLECTORS
SC	ALUMINIZED	MILD STL.	ALUMINUM
ER	ALUMINIZED	MILD STL.	STAINLESS
GX	STAINLESS	STAINLESS	STAINLESS

TUBES COLOR CODED ON THE END TO IDENTIFY ITS COMPOSITION
 RED-STAINLESS YELLOW-ALUMINUM BLUE-MILD STEEL

MODEL NUMBER	BTU/HR	OPERATING GAS PRESSURE
NATURAL GAS LP GAS		
SC/ER/GX12-U30	40,000	1.9"wc 6.7"wc
SC/ER/GX15-U30	50,000	3.0"wc 10.5"wc
SC/ER/GX18-U30	60,000	2.4"wc 6.7"wc
SC/ER/GX22-U30	75,000	3.8"wc 10.5"wc

4" AMBIRAD GAS INFRARED HEATER ASSEMBLY DETAIL

"U35"

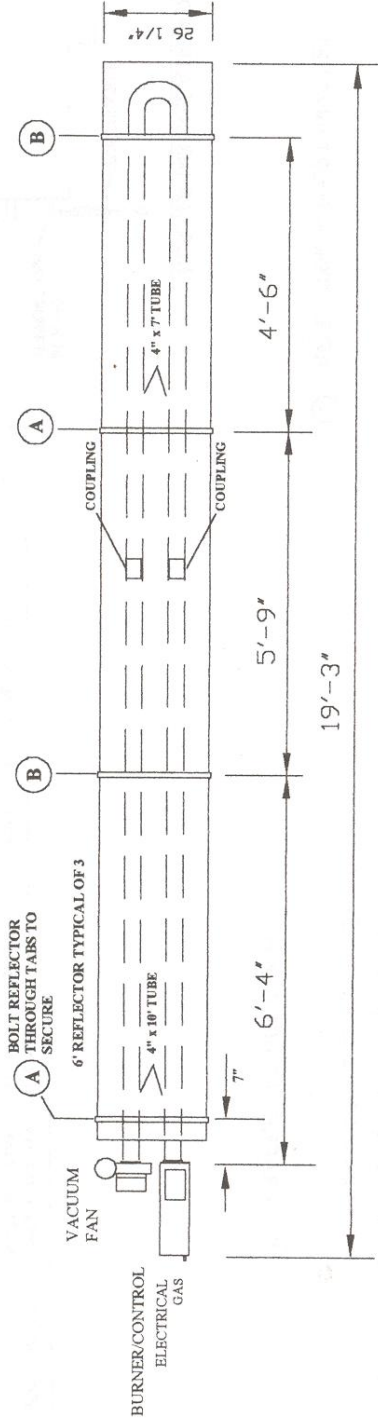

- (A) ALL A BRACKETS USED FOR SUSPENSION
- (B)

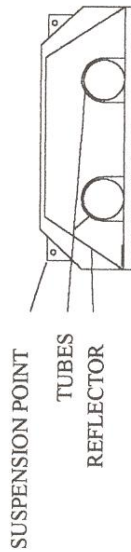

- (A) BRACKET WITH TABS FOR BOLTING REFLECTOR
- (B) BRACKET WITHOUT TABS

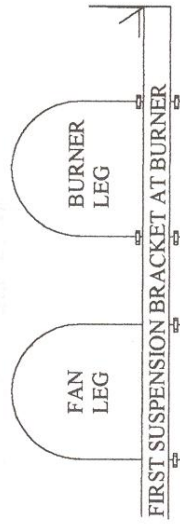

ON THE BURNER LEG ONLY, USE THE "U" BOLT PROVIDED WITH NUTS INSTALLED AND ADDITIONAL THREADS. SECURE BOLT TO BRACKET TO ALLOW FOR SLIPPAGE FOR EXPANSION AND CONTRACTION

BURNER INSTALLATION DETAIL

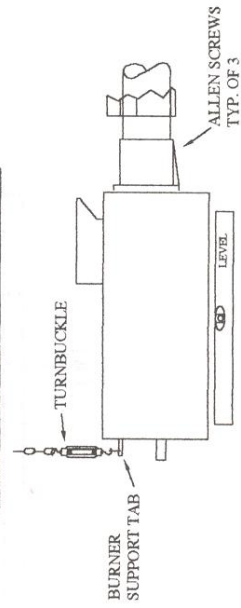

LEVEL THE BURNER USING THE TURNBUCKLE AT THE BURNER SUPPORT TAB BEFORE TIGHTENING THE BURNER HUB ALLEN SCREWS

SERIES	COMBUSTION TUBE	REMAINING TUBES	REFLECTORS
SC	ALUMINIZED	MILD STL.	ALUMINUM
ER	ALUMINIZED	MILD STL.	STAINLESS
GX	STAINLESS	STAINLESS	STAINLESS

TUBES COLOR CODED ON THE END TO IDENTIFY ITS COMPOSITION
 RED-STAINLESS YELLOW-ALUMINUM BLUE-MILD STEEL

MODEL NUMBER	BTU/HR	OPERATING GAS PRESSURE
SC/ER/GX29-U35	100,000	NATURAL GAS 4.9"wc LP GAS 10.0"wc
SC/ER/GX38-U35	130,000	4.9"wc 10.0"wc
SC/ER/GX44-U35	150,000	4.6"wc 10.0"wc

TABLE TWO

MODEL DESIGNATION		BURNER	BURNER INLET		FAN	NATURAL GAS		LIQUIFIED PETROLEUM	
INPUT KW/BTU	TUBE CONFIG.	BURNER CASTING	STD. AIR	OUTSIDE AIR	INLET HUB	INJECTOR		INJECTOR	
12/40,000	S-20	P-3034	AIS-0029	AIO-0029	FI-0334	P-1012		P-2012	
	S-25	P-3034	AIS-0029	AIO-0029	FI-0337	P-1012		P-2012	
	S-30	P-3034	AIS-0029	AIO-0029	FI-0337	P-1012		P-2012	
	U-20	P-3034	AIS-0029	AIO-0029	FI-0330	P-1012		P-2012	
	U-30	P-3034	AIS-0029	AIO-0029	FI-0330	P-1012		P-2012	
15/50,000	S-20	P-3034	AIS-0033	AIO-0033	FI-0337	P-1015		P-2015	
	S-25	P-3034	AIS-0029	AIO-0029	FI-0337	P-1015		P-2015	
	S-30	P-3034	AIS-0029	AIO-0029	FI-0337	P-1015		P-2015	
	U-20	P-3034	AIS-0033	AIO-0033	FI-0337	P-1015		P-2015	
	U-30	P-3034	AIS-0033	AIO-0033	FI-0334	P-1015		P-2015	
18/60,000	S-20	P-3034	AIS-0044	AIO-0044	FI-0350	P-1018		P-2018	
	S-25	P-3034	AIS-0033	AIO-0033	FI-0337	P-1018		P-2018	
	S-30	P-3034	AIS-0033	AIO-0033	FI-0337	P-1018		P-2018	
	S-40	P-3034	AIS-0033	AIO-0033	FI-0337	P-1018		P-2018	
	U-20	P-3034	AIS-0033	AIO-0033	FI-0344	P-1018		P-2018	
	U-30	P-3034	AIS-0033	AIO-0033	FI-0337	P-1018		P-2018	
22/75,000	S-20	P-3034	AIS-0044	AIO-0044	FI-0367	P-1022		P-2022	
	S-25	P-3034	AIS-0044	AIO-0044	FI-0350	P-1022		P-2022	
	S-30	P-3034	AIS-0044	AIO-0044	FI-0350	P-1022		P-2022	
	S-40	P-3034	AIS-0044	AIO-0044	FI-0344	P-1022		P-2022	
	U-20	P-3034	AIS-0044	AIO-0044	FI-0367	P-1022		P-2022	
	U-30	P-3034	AIS-0044	AIO-0044	FI-0350	P-1022		P-2022	
29/100,000	S-40	P-3084**	AIS-0058	AIO-0058	FI-0450	P-1029		P-2029	
	S-50	P-3084**	AIS-0058	AIO-0058	FI-0450	P-1029		P-2029	
	S-60	P-3084**	AIS-0058	AIO-0058	FI-0450	P-1029		P-2029	
	U-35	P-3084**	AIS-0058	AIO-0058	FI-0450	P-1029		P-2029	
38/130,000	S-40	P-3084**	AIS-0058	AIO-0058	FI-0467	P-1038		P-1038	
	S-50	P-3084**	AIS-0058	AIO-0058	FI-0467	P-1038		P-1038	
	S-60	P-3084**	AIS-0058	AIO-0058	FI-0467	P-1038		P-1038	
	U-35	P-3084**	AIS-0058	AIO-0058	FI-0467	P-1038		P-1038	
44/150,000	S-40	P-3084**	AIS-0058	AIO-0058	FI-0410	P-1044		P-1044	
	S-50	P-3084**	AIS-0058	AIO-0058	FI-0410	P-1044		P-1044	
	S-60	P-3084**	AIS-0058	AIO-0058	FI-0410	P-1044		P-1044	
	U-35	P-3084**	AIS-0058	AIO-0058	FI-0410	P-1044		P-1044	

*NOTE: THE 150,000 BTU BURNERS USE HIGH TEMPERATURE GASKET AIG-0200.

ALL OTHER MODELS USE GASKET AIG-0010.

**4" BURNER CASTING REQUIRES SLEEVE (P-2842-SUB).

AMBIRAD BURNER PARTS LIST

PART #		DESCRIPTION
1	P-3256.9	BURNER IGNITION CONTROL UNIT
2	P-2054	NATURAL GAS VALVE (SAME VALVE FOR LP)
	P-2060	GAS VALVE SOLENOIDS
3	P-0416	IGNITION CABLE (NOT SHOWN)
4	P-3256.5	SENSOR WIRE (NOT SHOWN)
5	P-3125	MAINS ELECTRICAL CONNECTOR
6	P-2176	AMBER INDICATOR LIGHT
7	P-2181	RED INDICATOR LIGHT
8	P-2192	VACUUM SWITCH
9	P-3149	ELECTRODE ASSEMBLY
10	P-5306	ELECTRODE ASSEMBLY SCREWS (2)
11	P-2217	VACUUM SWITCH CONNECTION SILICONE TUBING
12	P-2265	INJECTOR CARRIER
13	P-2267	VACUUM SWITCH CONNECTOR
14	P-3035	BURNER HEAD
15	P-3240	BURNER / CONTROL HOUSING, M.S. (S.S. AVAILABLE)
16	P-3276.6	SIDE COVER, MILD STEEL (STAINLESS STEEL AVAILABLE)
17	P-3263.1	CABLE CONNECTOR
18	P-3247	SITE GLASS
19	P-5452	ALLEN SCREW (2-3" HUB / 3-4" HUB / 1-FAN HUB)
20	FA-0100	MILD STEEL FAN ASSEMBLY (NO INLET HUB, SEE TABLE #2)
	FA-0200	STAINLESS STEEL FAN ASM (NO INLET HUB, SEE TABLE #2)
	FA-0300	STAINLESS STEEL FAN ASSEMBLY w/ TOTALLY ENCLOSED MOTOR (NO INLET HUB, SEE TABLE #2)
21	P-2305	STREET ELBOW $\frac{3}{8}$ " 45 DEGREE
22	P-2310	ELBOW $\frac{3}{8}$ " 45 DEGREE
23	P-2320	HEX BUSHING $\frac{3}{8}$ " X $\frac{1}{2}$ "
24	P-2360	5" X $\frac{1}{2}$ " NIPPLE
25	P-3247.1	SITE GLASS CLAMPS (2)
26	P-5363	M5 X 10mm SCREWS, PHILLIPS HEAD (13)
27	A-1427	$\frac{1}{2}$ " MANUAL SHUT OFF VALVE
28	P-5403/16	10mm X 20mm HEX BOLT WITH 10mm BOLT & WASHER (4 SETS)
29	P-300011	WIRING HARNESS (NOT SHOWN)
A	SEE TABLE 2	OUTSIDE AIR INTAKE LID
B	SEE TABLE 2	STANDARD AIR INTAKE LID
C	SEE TABLE 2	FAN INTAKE HUB
D	SEE TABLE 2	BURNER INTAKE GASKET
E	SEE TABLE 2	BURNER SUPPORT CASTING
F	SEE TABLE 2	GAS INJECTOR

SC/ER/GX BURNER BREAKDOWN

